



## **PREFORMED** LINE PRODUCTS

### **Section 5 – Fiber Optics: FIBERLIGN® Hardware for OPGW**

Table of Contents	Page
Fiber Optic Product Layout for OPGW .....	5-2
FIBERLIGN Dead-end for OPGW.....	5-3
FIBERLIGN Formed Wire Dead-end for OPGW.....	5-6
Ground Clamps.....	5-10
Optical Tension Device (OTD).....	5-11
FIBERLIGN Suspension for OPGW.....	5-12
FIBERLIGN Cushion Clamp for OPGW.....	5-17
FIBERLIGN Repair Rods for OPGW.....	5-20



# Fiber Optic Products

## OPGW Product Layout

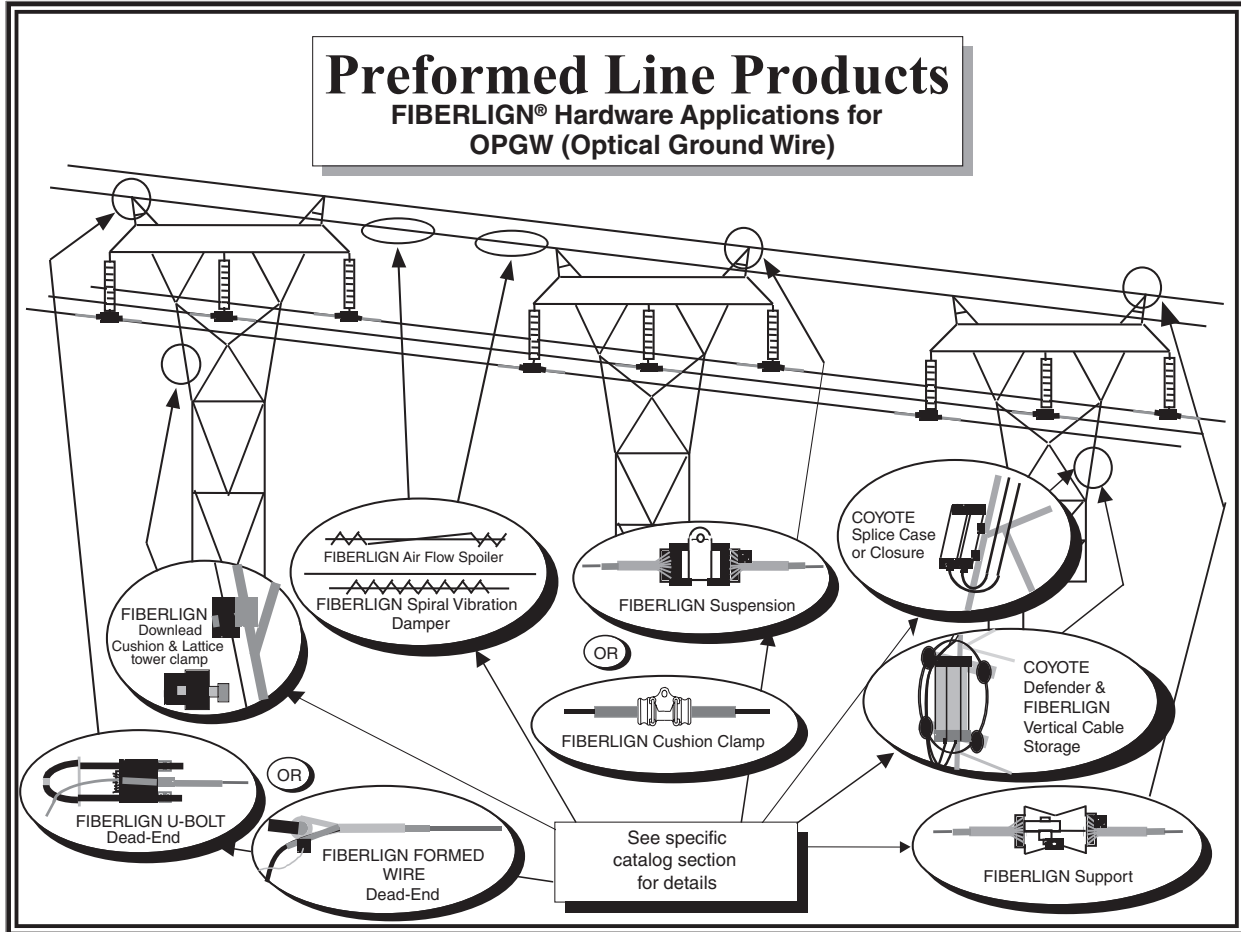

**Note:** Some OPGW hardware accessories can be found in section 7.

# FIBERLIGN® Dead-end for OPGW

**Retaining Rods:** Aluminum Covered Steel, with Conductive Grit Applied.

**Nuts:** Galvanized Steel

**U-bolt, Spacer Bar:** Galvanized Steel

**Housing:** Galvanized Iron

**Wedges:** Aluminum Alloy

**Grounding Bolt And Lock Washer:** (included but not shown): Galvanized Steel

## APPLICATION

The FIBERLIGN Dead-end is designed to terminate Optical Ground Wire (OPGW) while minimizing any compression stresses that may be transferred to the core or optical elements within. The Retaining Rods act with the Wedge and Housing to distribute the axial and compressive loading over a large area of the OPGW. Standard units have left-hand lay rods.

The FIBERLIGN® Dead-end sketch at the bottom of this page includes reference to the exposed rod length " $L_E$ " or the rod length beyond the housing. This dimension is listed in the catalog table to help with VORTX™ Damper placement.

The slotted Housing design allows for the application of the FIBERLIGN Dead-end at any location on the OPGW.

**Bonding:** Provisions for electrically bonding the OPGW to the supporting structure or ground lead are an integral part of the Housing. A 1" x 1/2"-13 UNC, 2A galvanized Grounding Bolt and Lock Washer are provided.

**Grounding Wire Assembly Options:** A 4' ground wire assembly can be connected from the FIBERLIGN Dead-end to the ground lead in your system. Two types of ground materials are offered (copper or aluminum). To included the preferred ground wire assembly in the same carton with the Dead-end, add the appropriate suffix code to the Dead-end catalog number.

**Adjustment:** The U-Bolt provides up to 18 inches of take-up to allow for tension adjustment and extra clearance distance without the need for external hardware such as a turnbuckle or extension links.

**Component Strength:** The value shown in the table on the following page reflects the strength of the standard housing and U-bolt. Higher strength requirements can be accommodated. Contact PLP® for more information.

**Holding Strength:** Specific holding strengths on an OPGW cable will depend upon that cable's internal construction design and composition of the materials used for the individual strands. The highest holding capabilities exist with cables that use all aluminum clad steel strands in a single layer. Use of multiple layers and/or aluminum alloy strands may reduce holding capabilities. Consult PLP for information regarding holding abilities of the FIBERLIGN OPGW Dead-end for a specific OPGW design.

## NOMENCLATURE

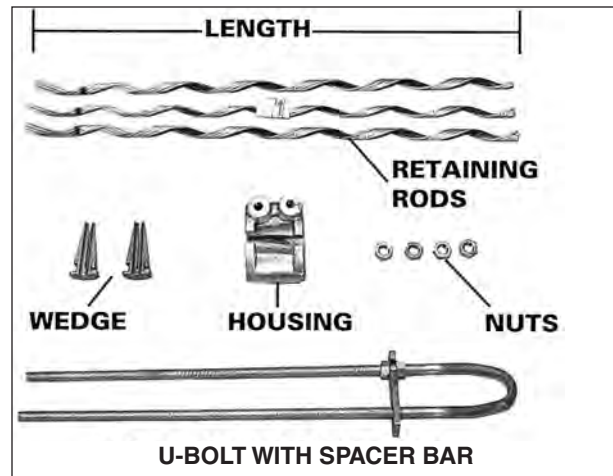

**Lay Direction:** Left-hand lay is standard. Custom right-hand lay units are available. Contact PLP with cable specifications for further information.

**Attachment Fittings:** The dead-end U-bolt component should be applied over pins, sheave wheels, or other fittings that have smooth contours, appropriate diameters and adequate strength for proper fit and support under loading conditions.

- For 5/8" U-bolts used in standard dead-ends designed for cable diameters less than or equal to .749" diameter – Adequate fitting or pin diameters range from 5/8" to 1-7/8".
- For 3/4" U-bolts used in standard dead-ends designed for cable diameters greater than .749" diameter cable - Adequate fitting or pin diameters range from 5/8" to 13/16".
- For either U-bolt size connected to a vang or structure plate, the holes in the plate should be chamfered - an example of an acceptable plate is maximum thickness of 1-1/16" (27 mm), Hole diameter 1" (25 mm), Chamfer 1/8" x 450) (3.2 mm x 450), and Installation clearance 1-15/16" (24 mm).

Consult PLP® for installation to other plates or fittings.

**Component Reuse:** The retaining rods and wedges may be reused once for retensioning after initial installation. The hardware components may be reused as desired if in good condition. Do not modify any component.

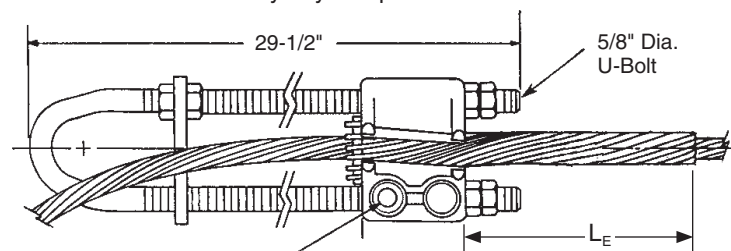

Threaded Hole (1/2-13 UNC, 7/8" deep) to fit class 2A Galvanized Bolt for Grounding Connection.



# FIBERLIGN® Dead-end for OPGW



## FIBERLIGN Dead-end for OPTICAL GROUND WIRE (OPGW) Patented

### Ordering Instructions:

Select the appropriate FIBERLIGN Dead-end from the catalog table in this section. Consult PLP® for designs for OPGW diameters, strengths, or lay directions not shown. Also call PLP for availability of all sizes and designs.

### Accessories:

Accessories may be included in the same container with the Dead-end by adding the appropriate suffix code. Ex. 2801312G, includes Dead-end with ground wire assembly, #710010016.

Catalog Number	Suffix Code	Description
710010016	<b>G</b>	4' long (1.2 m) #4(7W) copper ground wire with terminal on one end.
710010294	<b>GA</b>	4' (1.2 m) long 4/0 (7W) aluminum ground wire with terminal on one end.
710011205	<b>GA2</b>	5' (1.5 m) long 95 mm 2 (19W) aluminum ground wire with terminals at both ends.

**CAUTION:** Determine the appropriate material and size wire necessary to provide adequate grounding for your system before ordering the ground wire assemblies. For proper performance and personal safety be sure to select the proper ground wire before application.

# FIBERLIGN® Dead-end for OPGW

Catalog Number	Diameter Range				Overall Rod Length (in)	Rods per set	Subset	Color Code	Components Rated Strength (lbs)	Exposed Rod Length for (L <sub>E</sub> ) VORTX™ Placement	
	Min. (in)	Max. (in)	Min. (mm)	Max. (mm)						Damper (in)	Placement (mm)
280110266	.358	.374	9.1	9.5	24	9	3-3-3	Blue	25,000	21	533
2801300	.375	.391	9.5	9.9	24	9	3-3-3	Pink	25,000	21	533
2801301	.392	.410	10.0	10.3	24	9	3-3-3	Pink	25,000	21	533
2801302	.411	.425	10.4	10.7	26	10	3-3-4	White	25,000	23	584
2801303	.426	.443	10.8	11.2	26	10	3-3-4	White	25,000	23	584
2801304	.444	.460	11.3	11.6	27	10	3-3-4	Brown	25,000	24	609
2801305	.461	.477	11.7	12.0	27	10	3-3-4	Brown	25,000	24	609
2801306	.478	.494	12.1	12.5	29	11	3-4-4	Purple	25,000	26	660
2801307	.495	.511	12.6	12.9	29	11	3-4-4	Purple	25,000	26	660
2801308	.512	.528	13.0	13.3	31	12	3-3-3-3	Yellow	25,000	28	711
2801309	.529	.545	13.4	13.8	31	12	3-3-3-3	Yellow	25,000	28	711
2801310	.546	.562	13.9	14.2	32	12	3-3-3-3	Blue	25,000	29	737
2801311	.563	.579	14.3	14.6	32	12	3-3-3-3	Blue	25,000	29	737
2801312	.580	.596	14.7	15.1	34	12	3-3-3-3	Orange	25,000	31	787
2801313	.597	.613	15.2	15.5	34	12	3-3-3-3	Orange	25,000	31	787
2801314	.614	.630	15.6	15.9	36	11	3-4-4	Red	25,000	33	838
2801315	.631	.647	16.0	16.4	36	11	3-4-4	Red	25,000	33	838
2801316	.648	.664	16.5	16.9	38	12	3-3-3-3	Black	25,000	35	889
2801317	.665	.681	17.0	17.2	38	12	3-3-3-3	Black	25,000	35	889
2801318	.682	.698	17.3	17.7	40	12	3-3-3-3	Green	25,000	37	938
2801319	.699	.715	17.8	18.0	40	12	3-3-3-3	Green	25,000	37	938
2801320	.716	.732	18.1	18.5	41	12	3-3-3-3	Brown	25,000	38	965
2801321	.733	.749	18.6	18.9	41	12	3-3-3-3	Brown	25,000	38	965
2801322	.750	.766	19.0	19.4	59	12	3-3-3-3	Purple	45,000	56	1422
2801323	.767	.783	19.5	19.8	59	12	3-3-3-3	Purple	45,000	56	1422
2801324	.784	.800	19.9	20.2	64	12	3-3-3-3	Yellow	45,000	61	1549
2801325	.801	.817	20.3	20.7	64	12	3-3-3-3	Yellow	45,000	61	1549
2801326	.818	.834	20.8	21.1	66	13	3-3-3-4	Blue	45,000	63	1600
2801327	.835	.851	21.2	21.5	66	13	3-3-3-4	Blue	45,000	63	1600
2801328	.852	.868	21.6	22.0	70	12	3-3-3-3	Orange	45,000	67	1701
2801329	.869	.885	22.1	22.4	70	12	3-3-3-3	Orange	45,000	67	1701
2801330	.886	.902	22.5	22.8	72	12	3-3-3-3	Red	45,000	69	1753
2801331	.903	.919	22.9	23.2	72	12	3-3-3-3	Red	45,000	69	1753
2801332	.920	.936	23.3	23.8	74	13	3-3-3-4	Black	45,000	71	1803

See figure on page 5-3.



# FIBERLIGN® Formed Wire Dead-end for OPGW

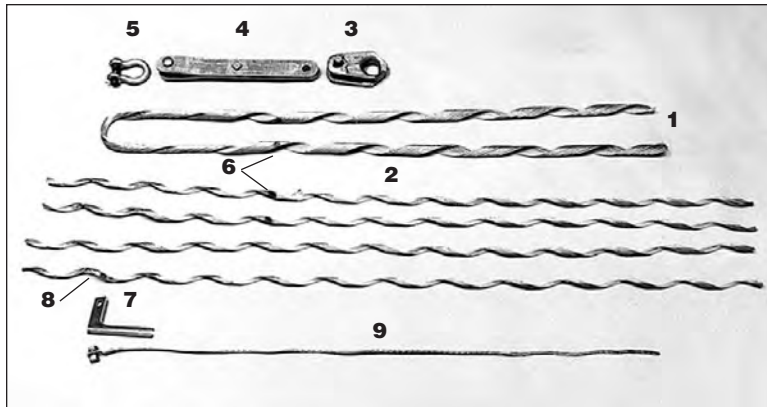

## NOMENCLATURE

- 1. Dead-End Component:** Aluminum Covered Steel with Grit Applied
- 2. Structural Reinforcing Rods:** Aluminum Covered Steel with Grit
- 3. Thimble Clevis:** Galvanized Ductile Iron
- 4. Extension Link (option):** Extension Link & Pin are galvanized steel or galvanized ductile iron. A stainless steel cotter key is provided to capture the pin
- 5. Anchor Shackle (option):** Galvanized steel forging
- 6. Color Code And Crossover Marks**
- 7. Current Transfer Tab:** High Strength Aluminum Alloy
- 8. Current Transfer Tab Location Mark**
- 9. Grounding Wire Assembly (option):** Copper or aluminum conductor with aluminum compatible lug

## APPLICATION

The FIBERLIGN Formed Wire Dead-end offers an alternate method for dead-ending OPGW. Unlike the FIBERLIGN® Dead-end “U-Bolt Type” design shown at the beginning of this section, the Formed Wire Dead-end uses two helically shaped formed wire components: an inner layer of Structural Reinforcing Rods and an outer layer Dead-end component. The FIBERLIGN® Formed Wire Dead-end does not provide take-up adjustment.

The formed wire inner and outer layer components are designed to transfer axial tensile loads and distribute radial compressive forces over the surface in contact with the OPGW to minimize effects on the central core and internal optical fibers.

Standard designs offered for left-hand lay single layer strand OPGW are listed in the table in this section. The standard Structural Reinforcing Rod component is right-hand lay and the standard Dead-end Component is left-hand lay.

The rated breaking strength of OPGW with multi-layer strand construction may exceed the rated holding strength of a Formed Wire Dead-end. Consult PLP before using this product for multi-layer applications.

Useful dimensions for VORTX™ damper placement are listed in the catalog table and shown in a reference drawing above the catalog table.

# FIBERLIGN® Formed Wire Dead-end for OPGW



## FIBERLIGN Formed Wire Dead-end Installed

### Current Transfer Tab:

The Current Transfer Tab provides direct electrical bonding between the OPGW and a ground lead. The Structural Reinforcing Rod Layer conveniently applies proper compression to retain the current transfer tab against the OPGW without fasteners. The current transfer tab has a 1/2" diameter bolt hole to accommodate a standard 1/2"-13, UNC bolt for compatible ground lug attachment.

The standard current transfer tab accommodates left-hand lay OPGW and is rated for 80 kA<sup>2</sup>S to 150 kA<sup>2</sup>S depending on size of dead-end unit. Right-hand lay units for special applications are also available. Consult PLP for specifics.

### Grounding Wire Assembly Options:

A 4' long ground wire with compression terminal, 1/2"-13 x 1" long bolt, 1/2"-13 nut, and lock washer can be provided. Two types of ground wire material are offered (copper or aluminum). To order the ground wire assembly with the Formed Wire Dead-end, add the appropriate suffix code to the catalog number (see catalog table in this section).

### Component Strength:

The strength of the thimble clevis, extension link, and anchor shackle are designed to meet or exceed the maximum rated holding strength of 25,000 pounds.

### Holding Strength:

Specific holding strengths on an OPGW cable will depend upon that cable's internal construction design and composition of the materials used for the individual strands. The highest holding capabilities exist with cable that use all aluminum clad steel strands in a single layer. Use of multi-layer and/or aluminum alloy strands may reduce holding capabilities. Consult PLP for information regarding holding abilities of the FIBERLIGN FORMED WIRE Dead-end for a specific OPGW design.

### Lay Direction:

Left-hand lay is standard. Right-hand lay units for right-hand lay OPGW are available. Contact PLP with cable specifications for further information.

### Attachment Fittings:

Dimensions of the thimble clevis provided (cat. no. TC-6F) are shown below. These are provided for proper selection of an extension link. PLP offers a 14" extension link as listed in the accessories section following the catalog table.

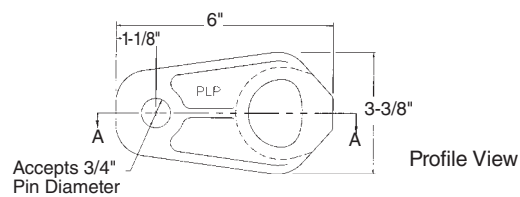
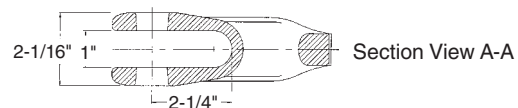

TC-6F Thimble Clevis

### Component Reuse:

Once installed, structural reinforcing rods and dead-end components may be removed and reinstalled once for repositioning purposes; do not reuse after this initial installation. The hardware components may be reused as long as they are in good condition. Do not modify any components.



# FIBERLIGN® Formed Wire Dead-end for OPGW

## Ordering Instructions:

Select the appropriate FIBERLIGN Formed Wire Dead-end for OPGW from the following table in this section.

## Accessories:

Ground wire assemblies and other hardware accessories may be ordered with the Formed Wire Dead-end by adding the appropriate SUFFIX CODE from the adjacent table. Note: Suffix code C4 is part of standard equipment and is included in the catalog number. The sequence for remaining accessory suffix codes is Extension Link "E2" followed by Anchor Shackle "S2" followed by Ground Wire Assembly "G" or "GA" Example – 2890001C4E2S2G includes a Formed Wire Dead-end with standard thimble clevis (C4), 14" extension link (E2), Anchor Shackle (S2) and copper ground wire assembly (G).

Suffix Code	Description
E2	14" (356 mm) Extension Link (Catalog no. 00060132), 25,000#
S2	Anchor Shackle (Catalog. no. 72905002), 25,000#
G	4' (1.212 m) long #4 (7W) Copper Ground Wire with terminal on one end. 1/2"-13x1-1/2" long galvanized steel bolt, hex nut and lock washer are included for attachment. (Catalog. no. 710010015). Rated for 35 KA²S.
GA	4' (1.212 m) long 4/0 (7W) Aluminum Ground Wire with terminal on one end. 1/2"-13x1-1/2" long galvanized steel bolt, hex nut and lock washer are included for attachment. (Catalog. no. 710010293). Rated for 80 KA²S.
GA2	5' (1.5 m) long 95mm² (19w) Aluminum Ground wire with terminals at both ends.

**CAUTION:** Determine appropriate material and size wire necessary to provide adequate grounding for your system before ordering the ground wire assemblies. For proper performance and personal safety be sure to select the proper ground wire before application.

Catalog Number	Diameter Range				Color Code	Rated Holding Strength* (Pounds)	Overall Structural Reinforcing Rod (SRR) Length in. (M)	Useful Dimensions for VORTX™ Damper Placement		
	Min. (in)	Max. (in)	Min. (mm)	Max. (mm)				SRR Rod Diameter in. (mm)	Dead-end Component Length "L1" in. (mm)	Partial SRR Length "L2" in. (mm)
2890020C4	0.355	0.399	9.0	10.1	Blue	20,000	44 (1.12)	.114 (2.9)	34 (863)	37.0 (939)
2890001C4	0.4	0.449	10.2	11.4	Blue	20,000	49 (1.24)	.114 (2.9)	36 (914)	40.5 (1028)
2890002C4	0.45	0.504	11.5	12.8	Red	25,000	54 (1.37)	.114 (2.9)	39 (990)	45.0 (1143)
2890003C4	0.505	0.555	12.9	14.1	Orange	25,000	58 (1.47)	.114 (2.9)	42 (1066)	47.5 (1206)
2890004C4	0.556	0.61	14.2	15.5	Black	25,000	63 (1.60)	.128 (3.2)	45 (1143)	51.5 (1308)
2890005C4	0.611	0.68	15.6	17.2	Green	25,000	68 (1.73)	.128 (3.2)	49 (1244)	56.0 (1422)
2890006C4	0.681	0.755	17.3	19.1	Pink	25,000	85 (2.16)	.144 (3.7)	64 (1625)	71.5 (1816)
2890007C4	0.756	0.83	19.2	21.1	Yellow	25,000	91 (2.31)	.144 (3.7)	68 (1727)	76.0 (1930)
2890008C4	0.831	0.925	21.2	23.5	Brown	25,000	98 (2.49)	.144 (3.7)	73 (1854)	81.5 (2057)
2890009C4	0.926	1.03	23.6	26.2	Purple	25,000	107 (2.72)	.144 (3.7)	79 (2006)	89.5 (2273)

\*Based on OPGW with all aluminum clad steel strands in a single layer. Left hand lay standard.

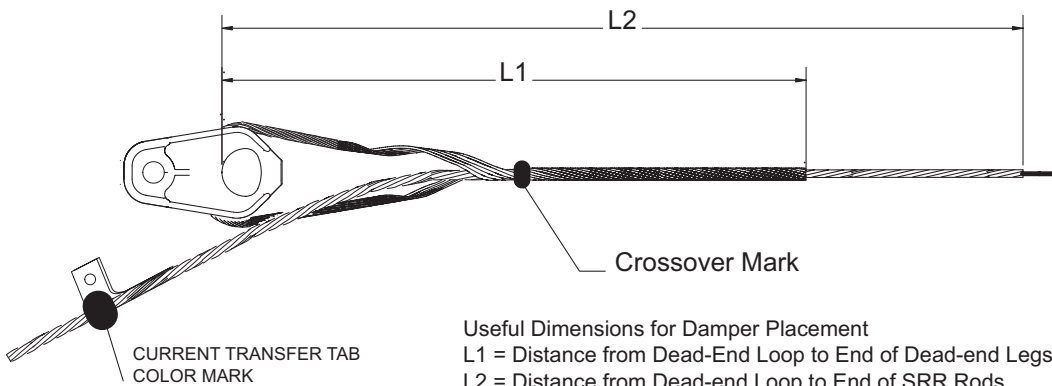

# FIBERLIGN® Formed Wire Dead-end for OPGW

## FIBERLIGN Formed Wire Dead-end Accessories

**Extension Link with Pin and Cotter Key**  
suffix code **E2**, catalog number **00060132**

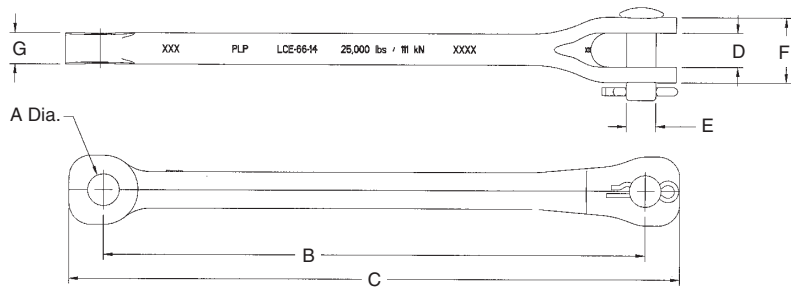

A (Dia.) In. (mm)	B In. (mm)	C In. (mm)	D In. (mm)	E In. (mm)	F In. (mm)	G In. (mm)	Ultimate Tensile Strength (lbs.)
13/16 (20.6)	14 (356)	16-1/2 max. (419)	7/8 (22.2)	3/4 (19.1)	1-43/64 (42.5)	51/64 max. (20.2)	25,000

**Anchor Shackle**  
suffix code **S2**, catalog number **72905002**

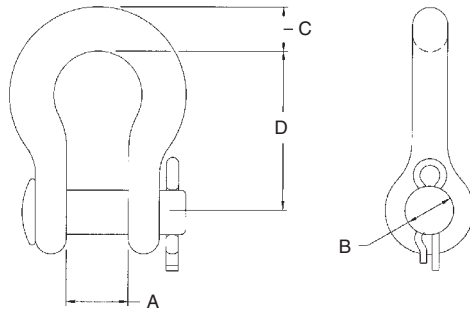

A Max. Width of Opening Inches (mm)	B Max. Pin Diameter Inches (mm)	C Shackle Thickness Inches (mm)	D Inches (mm)	Ultimate Strength (kN)
7/8" (22.2)	5/8" (15.9)	1/2" (12.7)	2-23/32 (69.1)	25,000 (111)

## Grounding Wire Assemblies

Catalog Number	Suffix Code	Dimensions Inches				Conductor		Attachment Ground Bolt Size (supplied w/nut and lock washer)
		L Length	D Conductor Diameter	d Lug Hole Diameter	e Lug Hole Diameter	Material	Type	
710010015	G	48 (1.2 m)	.232 (6 mm)	9/16 (14 mm)	-	Copper	#4 (7W)	1/2"-13 x 1-1/2" long
710010293	GA	48 (1.2 m)	.522 (13 mm)	9/16 (14 mm)	-	Aluminum	4/0 (7W)	1/2"-13 x 1-1/2" long
710011205	GA2	60 (1.5 m)	.495 (12.5)	17/32 (13.5 mm)	11/16 (17.5 mm)	Aluminum	95 mm <sup>2</sup> (7W)	M12 x 30 mm long M16 x 38 mm long
710012417	-	60 (1.5 m)	.528 (13.4)	17/32 (13.5 mm)	53/64 (21 mm)	Aluminum	4/0 (19W)	M18 x 40 mm long

### Copper

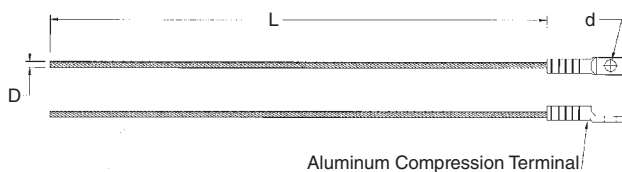

### Aluminum

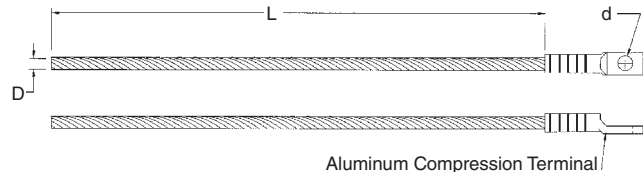

### Light Duty Lattice Tower Clamp

Catalog No. 710001045

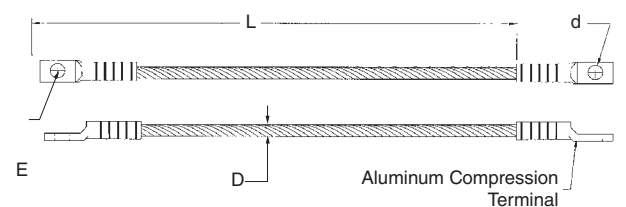
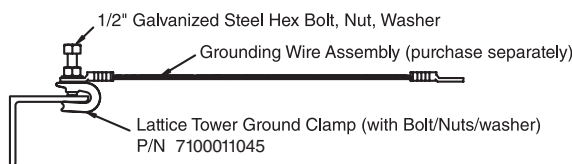



# Ground Clamps

## GENERAL RECOMMENDATIONS

- Designed For OPGW cable
- Installation torque: 25 ft.-lbs.
- Groove contains oxide inhibitor
- Aluminum alloy material
- 2 Grooves

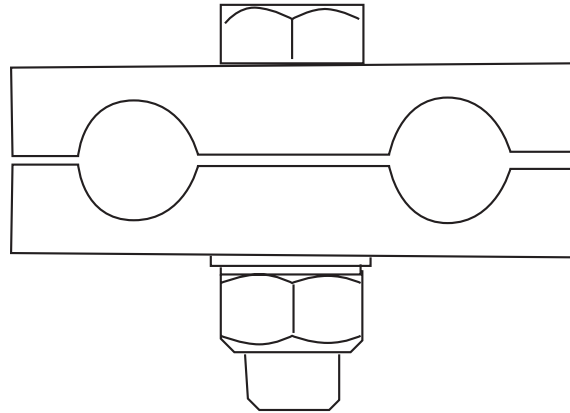

OPGW Diameter	Groove A:	
	Range mm	Inches
A	8.3 – 9.3	0.328 – 0.372
B	9.4 – 10.6	0.373 – 0.418
C	10.7 – 11.8	0.419 – 0.464
D	11.9 – 12.9	0.465 – 0.510
E	13.0 – 14.1	0.511 – 0.557
F	14.2 – 15.2	0.558 – 0.600
H	15.3 – 16.5	0.601 – 0.646
I	16.6 – 17.5	0.647 – 0.690
J	17.6 – 18.3	0.691 – 0.720
K	18.4 – 19.0	0.721 – 0.750
L	19.1 – 20.2	0.751 – 0.796

Ground Wire	Groove B:	
	Range mm	Inches
1	3.9 – 5.1	.155 – .203
2	5.2 – 9.8	.204 – .385
3	9.9 – 10.6	.386 – .418
4	10.7 – 11.8	.419 – .464
5*	11.9 – 13.0	.465 – .512
6	13.1 – 14.1	.513 – .557
7	14.2 – 15.2	.558 – .600
8	15.3 – 16.4	.601 – .646
9	16.5 – 17.5	.647 – .690

\*Code when using supplied 4/0 AL Ground Wire

**Ordering Guidelines**      **GC – XX**

Groove A Diameter \_\_\_\_\_

Groove B Ground Wire \_\_\_\_\_

# Optical Tension Device (OTD)

## For OPGW Fiber Cable

### Material

**Body:** High strength aluminum alloy

**Bolts:** High strength forged steel

**Bail:** High strength steel

The Optical Tension Device is designed for pulling OPGW fiber cable to final sag tension. Once the final sag has been achieved, a permanent type dead-end device should be installed promptly, followed by the removal of the tensioning device. This device should not be subjected to sag tension for an extended time period and it should never be utilized as a permanent dead-end device.

When installing the unit, partially tighten successive eye bolts in the following torque sequence:

First Sequence to 20 ft/lbs.

Second Sequence to 30 ft/lbs.

Final Torque to 40 ft/lbs.

### OPGW Cable Range

8.890 – 20.820 mm

0.350 – 0.820 inches

### Load Rating

50% of the rated cable breaking strength or 5000 lbs. (22.4 kN) whichever is less.

### Safety Tips

- Check for cracks and chipped areas along the cable groove and eyebolt areas. Do not reuse if any of these conditions exist
- Eyebolts should be kept clean and lubricated
- Conductor grooves should be clean and dry

After six months use and prior to each job, all Optical Tension Devices should be subjected to a pull test equal to its rated strength. If any damage is found the device should be disposed of or sent to PLP for possible rework and re-qualification.



### Ordering Guidelines OTD – X – XXX

OPGW Supplier \_\_\_\_\_

A – Alcoa - Fujikura

B – Brugg

C – Siemens

P – Prysmian

S – SFPOC

O – Other

Cable Diameter \_\_\_\_\_  
(in inches)



# FIBERLIGN® Suspension for OPGW

## NOMENCLATURE

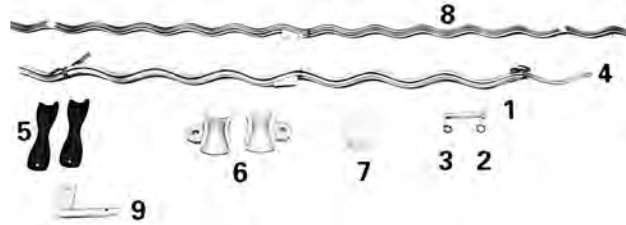

- 1. Bolt
- 2. Lock washer
- 3. Lock nut
- 4. Outer Rods
- 5. Insert
- 6. Housing
- 7. Strap
- 8. Structural Reinforcing Rods
- 9. Current Transfer Tab (for OPGW only)



Single Fiberlign Suspension for Optical Ground Wire (OPGW)

**Bolt, Washer, Lock Nut:** Galvanized Steel.

**Strap:** High-strength Aluminum Alloy.

**Insert:** An elastomer specifically formulated for resistance to ozone attack, weathering, extreme high and low temperature variations, and compression set. An Aluminum Alloy reinforcement is molded into the elastomer.

**Housing:** High-strength aluminum alloy casting

**Structural reinforcing rods and outer rods:** High-strength Aluminum Alloy.

**Current Transfer Tab:** (Supplied for OPGW Applications only) High Strength Aluminum Alloy.

## APPLICATION

The FIBERLIGN Suspension provides superior cable and fiber protection at the support point. The combination of Structural Reinforcing Rods, Outer Rods, boltless housing and resilient inserts reduces compression, clamping, and bending stresses on cable. Negative weather related cable motion, such as aeolian vibration, galloping, and wind sway are also minimized.

The FIBERLIGN Suspension is specially designed for supporting all installations of Optical Ground Wire (OPGW). Due to different performance requirements and cable characteristics OPGW and ADSS cables require different design FIBERLIGN Suspension Units.

For trunnion or bracket mounting, a FIBERLIGN Trunnion Support for OPGW is available. This unit has a housing designed to fit a trunnion cap or bracket with dimensions consistent with those specified in ANSI C29.7-1986, Class 57. Consult PLP® for specific information.



Trunnion mount FIBERLIGN Support for OPGW

# FIBERLIGN® Suspension for OPGW

## Double FIBERLIGN Suspension for Optical Ground Wire (OPGW)

The Current Transfer Tab provides direct electrical bonding between OPGW and a ground lead. The current transfer tab eliminates current transfer through components of the suspension unit. The standard current transfer tab accommodates left-hand lay OPGW. Right-hand lay and larger units for special applications are also available. Consult PLP for specifics.

The current transfer tab is not required or supplied for ADSS applications.

### Grounding Wire Assembly Options:

A 4' ground wire with compression terminal can be provided. This assembly can be connected from the FIBERLIGN Suspension to the ground lead in your system. Two types of ground wire materials are offered (copper or aluminum). To include the preferred ground wire assembly in the same carton with the current transfer tab, add the appropriate suffix code to the suspension catalog number (see table on next page).

### Ultimate Vertical Strength & Housing & Fitting Dimensions:

Refer to dimensional table in this section.

### Lay Direction:

Left-hand lay is standard although FIBERLIGN Suspension or Support units for OPGW may be used on right-hand lay OPGW at reduced slip loads, or custom ordered right-hand lay units are available.

### Slip Load:

When initially installed, the FIBERLIGN Suspension has a slip load of approximately 10-20% of a standard OPGW rated strength, but significantly higher loads can be expected after the unit has been in service for a period of time.



### Line Angles:

The maximum recommended line angle for a single FIBERLIGN Suspension is 30°. For OPGW line angles between 30° and 60°, the FIBERLIGN Suspension: Double is recommended, although double dead-ending is another option. Double units for ADSS cable are available on custom order although double dead-ends are also an option.

### Fittings:

An appropriate fitting such as a Y-clevis or clevis eye may be required to attach the Suspension unit to the structure or other hardware. These fittings must match the dimensions of the suspension housing. (See dimensional tables on next page)

### Fitting Suffix Codes:

To include the Y-clevis and clevis-eye fittings in the same carton with the suspensions, add the appropriate suffix code to the suspension catalog number (see table on next page).

### Component Reuse:

Once installed, do not reuse the rod components. The hardware components may be reused as desired as long as they are in good condition. Do not modify any components.



# FIBERLIGN® Suspension for OPGW

## Single and Double FIBERLIGN Suspensions for OPGW

### Ordering Instructions:

Select the appropriate FIBERLIGN Suspension for OPGW from the following table. Consult PLP® for trunnion or bracket type mounting OPGW applications and for the availability of all sizes and designs.

### Accessories and Fittings:

Ground wire assemblies and fittings may be included in the same container with the suspension by adding the appropriate SUFFIX CODE from the adjacent table.

**Note:** the suffix sequence is grounding wire first and fittings second. Example—4300100GYC includes a 4300100 single suspension with copper ground wire assembly (G) and Y-clevis eye (YC).

Suffix Code	Description
<b>G</b>	4' (1.2 m) long #4 (7W) Copper with terminal on one end. Catalog #710010015
<b>GA</b>	4' (1.2 m) long 4/0 (19W) Aluminum conductor with terminal on one end. Catalog #710010293
<b>GA2</b>	5' (1.5 m) long 95 mm <sup>2</sup> (7w) Aluminum Ground wire with terminals at both ends

**CAUTION:** Determine appropriate material and size wire necessary to provide adequate grounding for your system before ordering the ground wire assemblies. For proper performance and personal safety be sure to select the proper ground wire before application.

<b>S2</b>	Anchor Shackle (Catalog no 72905002), 25,000#
<b>YC</b>	One (1) Y-clevis to fit selected suspension. Single suspension applications.
<b>CE</b>	One (1) clevis-eye to fit selected suspension. Single suspension applications.
<b>CEYP</b>	Two (2) clevis-eyes with yoke plate to fit selected suspension. Double suspension applications.

Catalog Number		Diameter Range				Structural Reinforcement Rods					Outer Rods				
Single	Double	Min. (in)	Max. (in)	Min. (mm)	Max. (mm)	Single Length (in)	Double Length (in)	Rod Dia. (in)	Rods per set	Color Code	Single Length (in)	Double Length (in)	Rod Dia. (in)	Rods per set	Color Code
4300100	4300200	.354	.381	8.9	9.6	66	84	.146	9	Blue	42	60	.204	11	Blue
4300101	4300201	.382	.398	9.7	10.1	66	84	.146	9	Green	42	60	.204	11	Green
4300102	4300202	.399	.418	10.2	10.6	66	84	.146	10	Yellow	42	60	.204	11	Yellow
4300103	4300203	.419	.439	10.7	11.1	67	84	.146	10	Black	42	60	.204	11	Black
4300104	4300204	.440	.458	11.2	11.6	68	84	.146	11	White	43	61	.204	11	White
4300105	4300205	.459	.461	11.7	11.7	72	90	.167	10	Purple	46	64	.250	10	Orange
4300106	4300206	.462	.476	11.8	12.0	72	90	.167	10	Purple	46	64	.250	10	Purple
4300107	4300207	.477	.503	12.1	12.7	73	90	.146	11	Orange	46	64	.250	10	Orange
4300108	4300208	.504	.511	12.8	12.9	76	90	.146	12	Red	46	64	.250	10	Purple
4300109	4300209	.512	.536	13.0	13.6	76	94	.167	11	Blue	49	67	.250	11	Blue
4300110	4300210	.537	.559	13.7	14.1	77	94	.167	11	Green	49	67	.250	11	Green
4300111	4300211	.560	.565	14.2	14.3	77	94	.167	11	Green	49	67	.250	11	Green
4300112	4300212	.566	.573	14.4	14.5	79	102	.182	11	Black	54	76	.250	12	Black
4300113	4300213	.574	.598	14.6	15.1	79	102	.182	11	Black	54	76	.250	12	White
4300114	4300214	.599	.625	15.2	15.8	81	102	.182	11	Brown	54	76	.250	12	Brown
4300116	4300216	.626	.632	15.9	16.0	94	120	.204	11	Red	63	89	.310	11	Red
4300117	4300217	.633	.666	16.1	16.9	94	120	.204	11	Red	63	89	.310	11	Blue
4300118	4300218	.667	.682	17.0	17.3	94	120	.204	11	Yellow	63	89	.310	11	Green
4300119	4300219	.683	.710	17.4	18.0	94	120	.204	11	Yellow	63	89	.310	11	Yellow
4300120	4300220	.711	.728	18.1	18.4	94	120	.204	12	White	63	89	.310	12	Black
4300121	4300221	.729	.744	18.5	18.8	94	120	.204	12	White	63	89	.310	12	White
4300122	4300222	.745	.750	18.9	18.9	94	120	.204	12	White	63	89	.310	12	White
4300123	4300223	.751	.786	19.0	19.9	94	120	.204	12	Brown	63	89	.310	12	Brown
4300124	4300224	.787	.814	20.0	20.6	100	129	.250	11	Green	72	101	.365	11	Green
4300125	4300225	.815	.845	20.7	21.4	100	129	.250	11	Yellow	72	101	.365	11	Yellow
4300126	4300226	.846	.855	21.5	21.6	100	129	.250	11	Blue	72	101	.365	12	Blue
4300127	4300227	.856	.894	21.7	22.6	100	132	.250	12	Black	80	112	.365	12	Black
4300128	4300228	.895	.907	22.7	22.9	100	132	.250	12	White	80	112	.365	12	White
4300129	4300229	.908	.916	23.0	23.2	100	132	.250	12	Purple	80	112	.365	12	Purple
4300153	4300253	.917	.929	23.3	23.5	100	132	.250	12	Brown	80	112	.365	12	Brown
4300154	4300254	.930	.942	23.6	23.9	100	132	.250	12	Red	80	112	.365	12	Red
4300155	4300255	.943	.977	24.0	24.7	100	132	.250	13	Orange	80	112	.365	13	Orange

Left-hand lay standard

# FIBERLIGN® Suspension Housing Dimensions & Fittings

## FIBERLIGN Suspension: Dimensional Tables

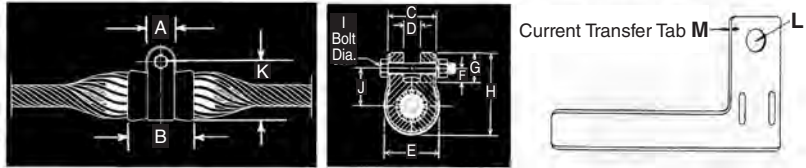

OPGW or ADSS Cable Diameter Range Inches (mm)		Dimensions Inches (mm)													Ultimate Vertical Strength (Lbs.)
Min.	Max.	A	B	C	D	E	F	G	H	I Bolt Dia.	J	K	L	M	
.354 (9)	.458 (11.6)	1-3/4 (44.5)	3-3/4 (95.3)	2-1/4 (57.2)	3/4 (19.1)	2-3/16 (55.6)	1 (25.4)	1-7/8 (47.6)	4-7/16 (112.7)	5/8 (15.9)	2-5/32 (54.8)	9/16 (14.3)	9/16 (14.3)	.090 (2.3)	15,000
.459 (11.7)	.565 (14.3)	2 (50.8)	4-17/32 (115.1)	2-11/16 (68.3)	7/8 (22.2)	3-5/16 (84.1)	1 (25.4)	2 (50.8)	5 (127)	5/8 (15.9)	2-11/32 (59.5)	4 (101.6)	9/16 (14.3)	.090 (2.3)	20,000
.566 (14.4)	.625 (15.8)	2 (50.8)	5 (127)	2-15/16 (74.6)	7/8 (22.2)	3-11/16 (93.7)	1 (25.4)	2 (50.8)	5-3/8 (136.5)	5/8 (15.9)	2-17/32 (64.3)	4-3/8 (111.1)	9/16 (14.3)	.090 (2.3)	20,000
.626 (15.9)	.786 (19.9)	2-1/4 (57.2)	5-1/2 (139.7)	3-1/2 (88.9)	1-3/16 (30.2)	4-5/32 (105.6)	1 (25.4)	2-1/8 (54)	5-29/32 (150)	5/8 (15.9)	2-45/64 (68.7)	4-25/32 (121.4)	9/16 (14.3)	.090 (2.3)	25,000
.787 (20)	.977 (24.8)	2-1/4 (57.2)	6 (152.4)	3-5/8 (92.1)	1-1/4 (31.8)	4-13/16 (122.2)	1-1/4 (31.8)	2-3/8 (60.3)	6-11/16 (169.9)	3/4 (19.1)	3-5/32 (80.2)	5-9/16 (141.3)	9/16 (14.3)	.090 (2.3)	25,000
.978 (24.9)	1.016 (25.8)	2-1/4 (57.2)	6-1/2 (165.1)	4-1/8 (104.8)	1-3/8 (34.9)	5-1/16 (128.6)	1-1/8 (28.6)	2-1/4 (57.2)	6-5/8 (168.3)	3/4 (19.1)	2-21/32 (67.5)	5-1/2 (139.7)	N/A	N/A	25,000
1.017 (25.9)	1.057 (26.8)	2-1/4 (57.2)	6-1/2 (165.1)	4-1/8 (104.8)	1-3/8 (34.9)	5-1/16 (128.6)	1-1/8 (28.6)	2-1/4 (57.2)	6-5/8 (168.3)	3/4 (19.1)	2-21/32 (67.5)	5-1/2 (139.7)	N/A	N/A	25,000
1.058 (26.9)	1.079 (27.4)	2-1/2 (63.5)	7 (177.8)	4-11/16 (119.1)	2-1/4 (57.2)	5-19/32 (142.1)	1-1/8 (28.6)	2-3/8 (60.3)	7-1/4 (184.2)	3/4 (19.1)	3-3/16 (81)	6 (152.4)	N/A	N/A	25,000
1.08 (27.5)	1.112 (28.2)	2-1/2 (63.5)	7 (177.8)	4-11/16 (119.1)	2-1/4 (57.2)	5-19/32 (142.1)	1-1/8 (28.6)	2-3/8 (60.3)	7-1/4 (184.2)	3/4 (19.1)	3-3/16 (81)	6 (152.4)	N/A	N/A	25,000
1.113 (28.3)	1.149 (29.2)	2-1/2 (63.5)	7 (177.8)	4-11/16 (119.1)	2-1/4 (57.2)	5-19/32 (142.1)	1-1/8 (28.6)	2-3/8 (60.3)	7-1/4 (184.2)	3/4 (19.1)	3-3/16 (81)	6 (152.4)	N/A	N/A	25,000
1.15 (29.3)	1.19 (30.2)	2-1/2 (63.5)	7 (177.8)	4-11/16 (119.1)	2-1/4 (57.2)	5-19/32 (142.1)	1-1/8 (28.6)	2-3/8 (60.3)	7-1/4 (184.2)	3/4 (19.1)	3-3/16 (81)	6 (152.4)	N/A	N/A	25,000

### Fittings:

The dimensions of a fitting must correspond to some of the dimensions of the housing of the FIBERLIGN Suspension unit in order to provide proper fit. To select the proper size fitting, identify the outside diameter of the OPGW or ADSS

cable and select the appropriate fitting from these tables. DO NOT use the tables in the ARMOR-GRIP® Suspension section of this catalog.

### Clevis Eye

Catalog Number	OPGW or ADSS Cable Diameter Range		General Dimensions							Ultimate Vertical Strength (Lbs.)
	Min.-Max. (in)	Min.-Max. (mm)	A in (mm)	B in (mm)	C in (mm)	D in (mm)	E in (mm)	F in (mm)	G in (mm)	
CE-5259	.354-.458	9-11.6	3-1/8 (79.4)	1/2 (12.7)	11/16 (17.5)	1-1/2 (38.1)	1-1/2 (38.1)	5/8 (15.9)	13/16 (20.6)	15,000
CE-5261	.459-.625	11.7-15.9	3-1/8 (79.4)	3/4 (19.1)	11/16 (17.5)	1-1/2 (38.1)	1-1/2 (38.1)	5/8 (15.9)	13/16 (20.6)	20,000
CE-5105	.626-1.057	16.0-26.8	3-1/8 (79.4)	1-1/16 (27)	13/16 (20.6)	1-1/2 (38.1)	1-1/2 (38.1)	5/8 (15.9)	13/16 (20.6)	25,000
CE-5106	1.058-1.208	26.9-30.7	3-1/8 (79.4)	2-1/8 (54)	13/16 (20.6)	1-1/2 (38.1)	1-1/2 (38.1)	5/8 (15.9)	13/16 (20.6)	25,000

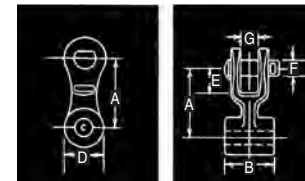
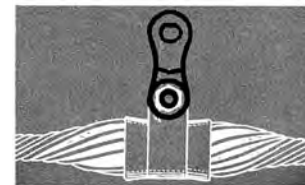

### Y-Clevis Eye

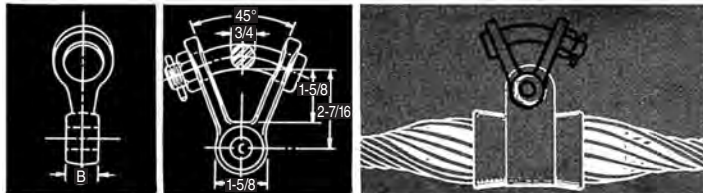

Catalog Number	OPGW or ADSS Cable Diameter Range		General Dimensions		Ultimate Vertical Strength (lbs.)
	Min.-Max. (in)	Min.-Max. (mm)	B in (mm)	C in (mm)	
YC-5206	.354-.458	9.0-11.6	5/8 (15.9)	11/16 (17.5)	15,000
YC-5207	.459-.625	11.7-15.9	3/4 (19.1)	11/16 (17.5)	20,000
YC-5209	.626-1.057	16.0-26.8	1-1/16 (27)	13/16 (20.6)	25,000
YC-5211	1.058-1.208	26.9-30.7	2-1/8 (54)	13/16 (20.6)	25,000



# FIBERLIGN<sup>®</sup> Suspension Housing Dimensions & Fittings

## FIBERLIGN Suspension: Double Dimensional Tables

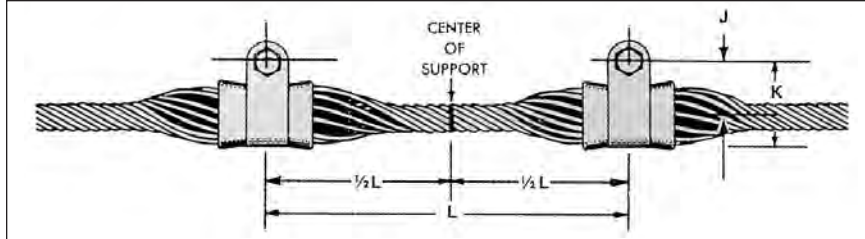

OPGW or ADSS Cable Diameter Range		Dimensions			Ultimate Vertical Strength (Lbs.)
Min.-Max. (in)	Min.-Max. (mm)	J in. (mm)	K in. (mm)	L in. (cm)	
.354-.458	9.0-11.6	2-5/32 (54.8)	3-9/16 (90.4)	18 (45.7)	30,000
.459-.565	11.7-14.4	2-11/32 (59.5)	4 (101.6)	18 (45.7)	40,000
.566-.625	14.5-15.9	2-17/32 (64.3)	4-3/8 (111.1)	22 (55.9)	40,000
.626-.786	16.0-20.0	2-45/64 (68.7)	4-25/32 (121.4)	26 (66.0)	50,000
.787-.855	20.1-21.7	3-5/32 (80.2)	5-9/16 (141.3)	29 (73.7)	50,000
.856-1.057	21.8-26.8	2-31/32 (75.4)	5-1/2 (139.7)	32 (81.3)	50,000
1.058-1.208	26.9-30.7	3-3/16 (81.0)	6 (152.4)	37 (94.0)	50,000

### Fittings

The "L" dimension of a Yoke Plate must match the "L" dimension between the two housings of the Double Suspension unit. Identify the outside diameter of the OPGW or ADSS cable and select the proper "L" dimension and Yoke Plate from these tables. **DO NOT** use the tables in the ARMOR-GRIP<sup>®</sup> Suspension section of this catalog.

A Fitting, such as a Clevis Eye, is required between each Suspension housing and the Yoke Plate. Refer to the tables on page 5-16 for proper fitting selection. Another fitting may be required between the Yoke Plate and structure.

### Yoke Plate

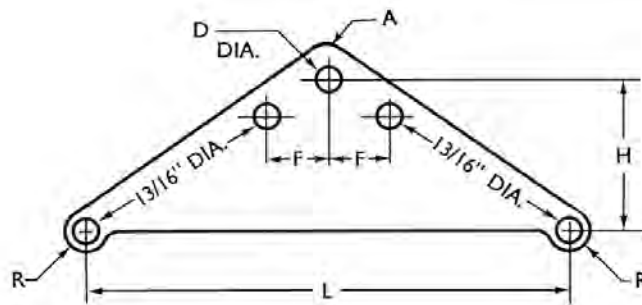
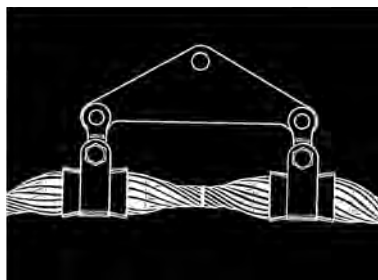

Catalog Number	OPGW or ADSS Cable Diameter Range		Dimensions						Plate Thickness in. (mm)
	Min.-Max. (in)	Min.-Max. (mm)	L in. (cm)	H in. (cm)	D in. (mm)	R in. (mm)	Radius A in. (mm)	F in. (cm)	
YP-5908	.354-.565	9.0-14.4	18 (45.7)	6-1/4 (15.9)	1 (25.4)	15/16 (23.8)	1-1/4 (31.8)	3-1/2 (8.9)	5/8 (15.9)
YP-5909	.566-.625	14.5-15.9	22 (55.9)	7-1/4 (18.4)	1 (25.4)	15/16 (23.8)	1-1/4 (31.8)	4-3/16 (10.6)	5/8 (15.9)
YP-5910	.626-.786	16.0-20.0	26 (66.0)	8-1/2 (21.6)	1 (25.4)	15/16 (23.8)	1-1/4 (31.8)	4-15/16 (12.5)	3/4 (19.1)
YP-5911	.787-.855	20.1-21.7	29 (73.7)	9-1/2 (24.1)	1 (25.4)	15/16 (23.8)	1-1/4 (31.8)	5-1/2 (14.0)	3/4 (19.1)
YP-5912	.856-1.057	21.8-26.8	32 (81.3)	10-1/2 (26.7)	1 (25.4)	15/16 (23.8)	1-1/4 (31.8)	6-1/8 (15.6)	3/4 (19.1)
YP-5913	1.058-1.208	26.9-30.7	37 (94.0)	11-3/4 (29.8)	1 (25.4)	15/16 (23.8)	1-1/4 (31.8)	7-1/16 (17.9)	3/4 (19.1)

# FIBERLIGN® Cushion Clamp for OPGW

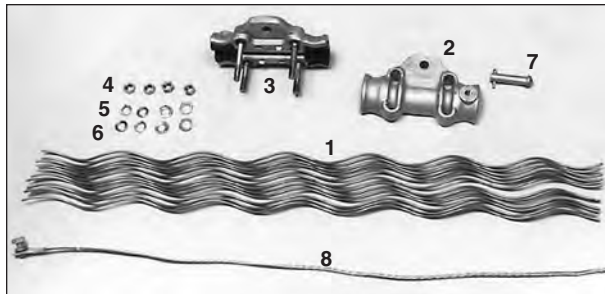

FIBERLIGN Cushion Clamp installed

## NOMENCLATURE

1. **Structural Reinforcing Rods:** High strength aluminum alloy.
2. **Cushion Clamp (keeper half):** An aluminum alloy clamp half with two factory installed elastomer cushion inserts and a 1/2"-13 female threaded boss for ground wire attachment. A galvanized 1/2"-13 x 3/4" long grounding bolt and lock washer are provided.
3. **Cushion Clamp (U-bolt half):** An aluminum alloy clamp half with two factory installed elastomer cushion inserts and two captured 1/2"-13 galvanized steel U-bolts.
4. **1/2"-13 Hex Nuts (4):** Galvanized steel.
5. **Lock Washers (4):** Galvanized steel.
6. **Flat Washers (4):** Galvanized steel.
7. **Pin and Cotter Key:** Pin is galvanized steel and Cotter Key is stainless steel.
8. **Grounding Wire Assembly (ordered separately)**

## APPLICATION

The FIBERLIGN Cushion Clamp provides excellent protection to OPGW at support points. The combination of the Structural Reinforcing Rods and the elastomer inserts at the ends of the clamp body halves reduces bending stresses on the OPGW during aeolian vibration or galloping activity.

### Bonding:

Provisions for electrically bonding the OPGW to the supporting structure or ground lead are an integral part of the keeper half. The 1/2"-13 x 3/4" long bolt and lock washer are provided with the keeper half for lug terminal attachment.

### Grounding Wire Assembly Options:

A 4' ground wire with compression terminal can be provided. Two types of ground wire material are offered (copper or aluminum). The Ground Wire assemblies may be ordered with the Cushion Clamp by adding the appropriate suffix code (see next page).

### Ultimate Vertical Strength & Dimensions:

The ultimate vertical strength of the Cushion Clamp body is 20,000 pounds (89 kN). See the table on page 5-19 for dimension of body and associated fittings.

### Lay Direction:

The Cushion Clamp can accommodate either left-hand lay or right-hand lay OPGW.

### Slip Load:

The Cushion Clamp has a slip load of approximately 10-20% of the OPGW rated strength.

### Line Angles:

The maximum recommended line angle for a single FIBERLIGN Cushion Clamp is 30°. For OPGW line angles between 30° and 60°, the Cushion Clamp double is available, although double dead-ending is another option.

### Fittings:

An appropriate fitting such as a Y-Clevis, Clevis-Eye, or Anchor Shackle may be required to attach the Cushion Clamp to the structure or other hardware. To include these fittings, add the appropriate suffix code to the catalog number (see next page).

### Component Reuse:

Once installed, do not reuse the Structural Reinforcing Rods. The hardware components may be reused as long as they are in good condition. Do not modify any components.



# FIBERLIGN® Cushion Clamp for OPGW

## Single and Double FIBERLIGN Cushion Clamp for OPGW

### Ordering Instructions:

Select the appropriate FIBERLIGN Cushion Clamp for OPGW from the following table.

### Accessories and Fittings:

Ground wire assemblies and fittings may be ordered with the Cushion Clamp by adding the appropriate SUFFIX CODE from the adjacent table. Note: the suffix sequence is ground wire first and fittings second. Example - 4700100GYC includes a 4700100 Single Cushion Clamp with copper ground wire assembly (G) and Y-Clevis (YC).

Suffix Code	Description
G	4' (1) long #4 (7W) Copper Ground Wire with terminal on one end. Catalog No. 710010016
GA	4' (1) long 4/0 (7W) Aluminum Ground Wire with terminal on one end. Catalog No. 710010294
GA2	5' (1.5) long 95 mm <sup>2</sup> (19W) Aluminum Ground Wire with terminals at both ends

**CAUTION:** Determine appropriate material and size wire necessary to provide adequate grounding for your system before ordering the ground wire assemblies. For proper performance and personal safety be sure to select the proper ground wire before application.

S2	Anchor Shackle (Catalog no 72905002), 25,000#
YC	One (1) Y-clevis to fit selected suspension. Single suspension.
CE	One (1) clevis-eye to fit selected suspension. Single suspension.
CEYP	Two (2) clevis-eyes with yoke plate to fit selected suspension. Double suspension.
GA2	5' (1.5) long 95 mm <sup>2</sup> (19W) Aluminum Ground wire with terminals at both ends.

Catalog Number		Diameter Range				Structural Reinforcing Rods				Color Code
Single	Double	Min. (in)	Max. (in)	Min. (mm)	Max. (mm)	Single Length	Double Length	Rod Dia.	Rods per Set	
4700100	4700200	0.376	0.387	9.6	9.8	31	60	0.204	7	Orange
4700101	4700201	0.388	0.429	9.9	10.9	32	61	0.182	8	Red
4700102	4700202	0.430	0.459	11.0	11.6	33	62	0.167	9	Black
4700103	4700203	0.460	0.482	11.7	12.2	34	63	0.154	10	Green
4700104	4700204	0.483	0.507	12.3	12.8	35	64	0.182	10	Yellow
4700105	4700205	0.508	0.537	12.9	13.6	36	65	0.167	11	Purple
4700106	4700206	0.538	0.563	13.7	14.3	37	66	0.154	12	Pink
4700107	4700207	0.564	0.585	14.4	14.8	39	68	0.182	11	Brown
4700108	4700208	0.586	0.615	14.9	15.6	40	69	0.167	12	Blue
4700109	4700209	0.616	0.641	15.7	16.3	41	70	0.154	13	Orange
4700110	4700210	0.642	0.664	16.4	16.8	44	73	0.182	12	Red
4700111	4700211	0.665	0.694	16.9	17.6	45	74	0.167	13	Black
4700112	4700212	0.695	0.720	17.7	18.3	46	75	0.154	15	Green
4700113	4700213	0.721	0.742	18.4	18.8	48	77	0.182	13	Yellow
4700114	4700214	0.743	0.772	18.9	19.6	50	79	0.167	14	Purple
4700115	4700215	0.773	0.798	19.7	20.2	51	80	0.154	15	Pink
4700116	4700216	0.799	0.822	20.3	20.8	52	81	0.182	14	Brown
4700117	4700217	0.823	0.855	20.9	21.7	54	83	0.167	16	Blue
4700118	4700218	0.856	0.885	21.8	22.4	55	84	0.146	19	Orange
4700119	4700219	0.886	0.911	22.5	23.1	56	85	0.167	16	Red
4700120	4700220	0.912	0.941	23.2	23.9	57	86	0.154	19	Black
4700121	4700221	0.942	0.975	24.0	24.7	58	87	0.146	20	Green
4700122	4700222	0.976	1.005	24.8	25.5	60	89	0.167	18	Yellow
4700123	4700223	1.006	1.034	25.6	26.3	61	90	0.154	20	Purple

# FIBERLIGN® Cushion Clamp for OPGW

## FIBERLIGN Cushion Clamp Dimensions

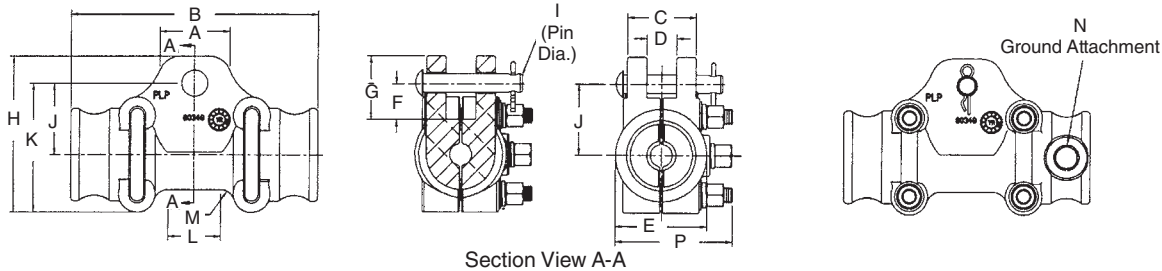

Dimensions Inches (mm)															Ultimate Vertical Strength (Single) lbs.
A	B	C	D	E	F	G	H	I	J	K	L	M	N	P	
2-23/64 (59.9)	8-11/32 (211.9)	2-11/32 (59.5)	59/64 (23.4)	3-7/64 (79.0)	1-5/32 (29.4)	2-1/8 (54.0)	5-1/4 (133.4)	5/8 (15.9)	2-11/32 (59.5)	3-41/64 (92.5)	1-25/32 (45.2)	31/64 (12.3)	1/2-13 UNC	3-15/16 (100.0)	20,000

## FIBERLIGN Cushion Clamp: Double

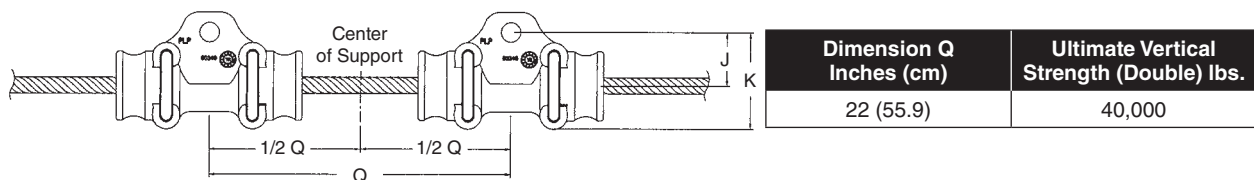

## Fittings & Yoke Plate

### Clevis Eye

Catalog Number	Dimensions Inches (mm)							Ultimate Vertical Strength (lbs.)
	A	B	C	D	E	F	G	
CE-5261	3-1/8 (79.4)	3/4 (19.1)	11/16 (17.5)	1-1/2 (38.1)	1-1/2 (38.1)	5/8 (15.9)	13/16 (20.6)	20,000

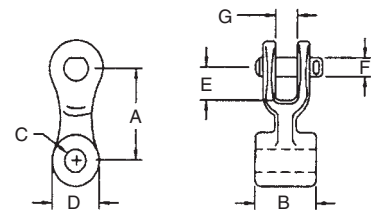

### Yoke Plate

Catalog Number	Dimensions Inches (cm)						Plate Thickness
	L	H	D	R	Radius A	F	
YP-5909	22 (55.9)	7-1/4 (18.4)	1 (25.4)	15/16 (23.8)	1-1/4 (31.8)	4-3/16 (10.6)	5/8 (15.9 mm)

### Y-Clevis Eye

Catalog Number	Dimensions Inches (mm)		Ultimate Vertical Strength (lbs.)
	B	C	
YC-5207	3/4 (19.1)	11/16 (17.5)	20,000

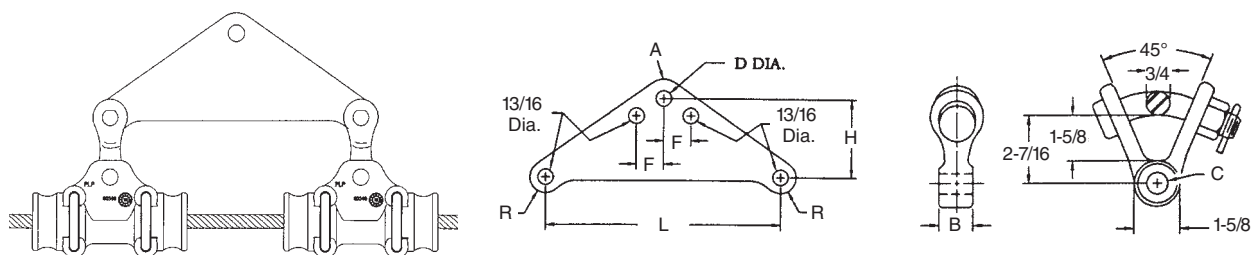



# FIBERLIGN® Repair Rods for OPGW

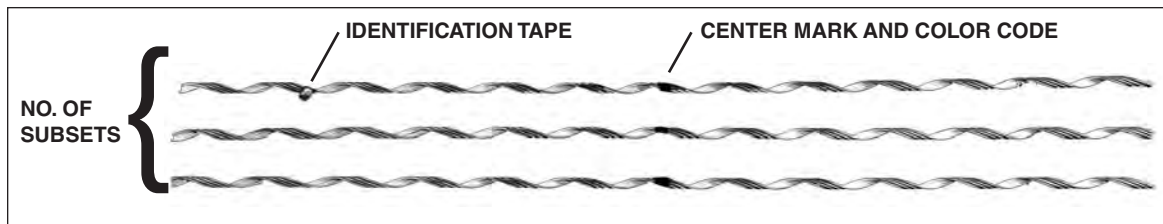

## NOMENCLATURE

**Subsets:** Individual aluminum clad steel rods assembled into groups. The bore is coated with conductive grit.

**Center Mark:** Establishes recommended alignment of rods during application.

**Color code:** Provides identification for application of OPGW size that corresponds to the information appearing in the table below.

**Identification Tape:** Shows catalog number, nominal sizes.

## GENERAL RECOMMENDATIONS

FIBERLIGN Repair Rods are designed as a single-component, outer layer assembly for use on OPGW and are intended for repair of the outer mechanical strand members on an OPGW cable. **This is not an optical repair product.**

These OPGW Repair Rods are not designed or tested as splices for use on all-metal overhead shield wire and are not intended for that application.

**Restorative-Repair:** These Repair Rods will provide varying levels of mechanical and electrical repair depending upon the specific construction, stranding and material of the OPGW.



The extent of mechanical damage that the product can repair for single layer OPGW is up to 50% of the cable rated strength. The 50% rating is established by PLP® based on repair rod performance. Contact the OPGW cable manufacturer to verify the extent of damage that the specific cable design can survive without jeopardizing the performance of the fiber optic elements. If the cable manufacturer limits the repair level to lower than 50%, limit the use of the repair rod to the lower level for that specific cable. Consult PLP for further details.

Lay direction of the Repair Rods should be the same as the outer strands of the OPGW. Left-hand lay is standard, consult PLP for right-hand lay designs.

Repair Rods					
Catalog Number	Diameter Range (inch)	Diameter Range (mm)	Color Code	Length	
				in	M
3600100	.354-.385	8.9-9.7	Red	45	1.14
3600101	.386-.422	9.8-10.7	Black	48	1.22
3600102	.423-.460	10.8-11.6	Orange	50	1.27
3600103	.461-.505	11.7-12.8	Green	54	1.37
3600104	.506-.550	12.9-13.9	Blue	61	1.55
3600105	.551-.602	14.0-15.2	Yellow	65	1.65
3600106	.603-.660	15.3-16.7	Brown	70	1.78
3600107	.661-.719	16.8-18.2	Purple	74	1.88
3600108	.720-.785	18.3-19.9	Pink	80	2.03
3600109	.786-.850	20.0-21.5	Red	86	2.18
3600110	.851-.933	21.6-23.6	Black	94	2.39
3600111	.934-1.020	23.7-25.9	Orange	102	2.59

*Left-hand lay standard*