

MIL-C-83522/16 and /17 Military ST Fiber Optic Connector and Adapter



MIL-C-83522/16-DNX
ST Connector

STRAN Technologies' MIL ST connectors and adapter are designed for harsh environment applications including military shipboard, aerospace, and land based optical data communication systems. The connectors are available in both Multimode and Singlemode configurations and have been tested to meet the requirements of military specification MIL-C-83522/16-DNX and /16-DNY respectively. STRAN has also qualified the MIL ST-ST Adapter to the specification MIL-C-83522/17-NY. Some of the applications supported by STRAN's MIL ST's and adapter include:

- Navy Shipboard applications
- Deployable military tactical networks
- UAV control and command centers
- Homeland security and surveillance
- Harsh industrial installations
- Emergency restoration systems
- Cabinet mounted communication systems
- Mobile tactical networks

Some of the key features of this connector and adapter include:

- 303 or 316 Stainless steel construction
- Pre-radiused zirconia ferrule to minimize field polishing
- Higher spring force in order to meet the demanding MIL-C-83522 vibration and shock requirements
- Field installable and maintainable
- Components are DFARS compliant, machined, finished and assembled in the USA
- Threaded boots, black for Multimode and blue for Singlemode
- Compatible with MIL-STD-2042B Navy standard termination methods and all commonly used hand and machine polishing equipment



M83522/17-NY
ST-ST Adapter

MILITARY TACTICAL

MILITARY SHIPBOARD

ENERGY

AEROSPACE

COMMERCIAL

M83522/16 and /17 Military ST Fiber Optic Connector and Adapter

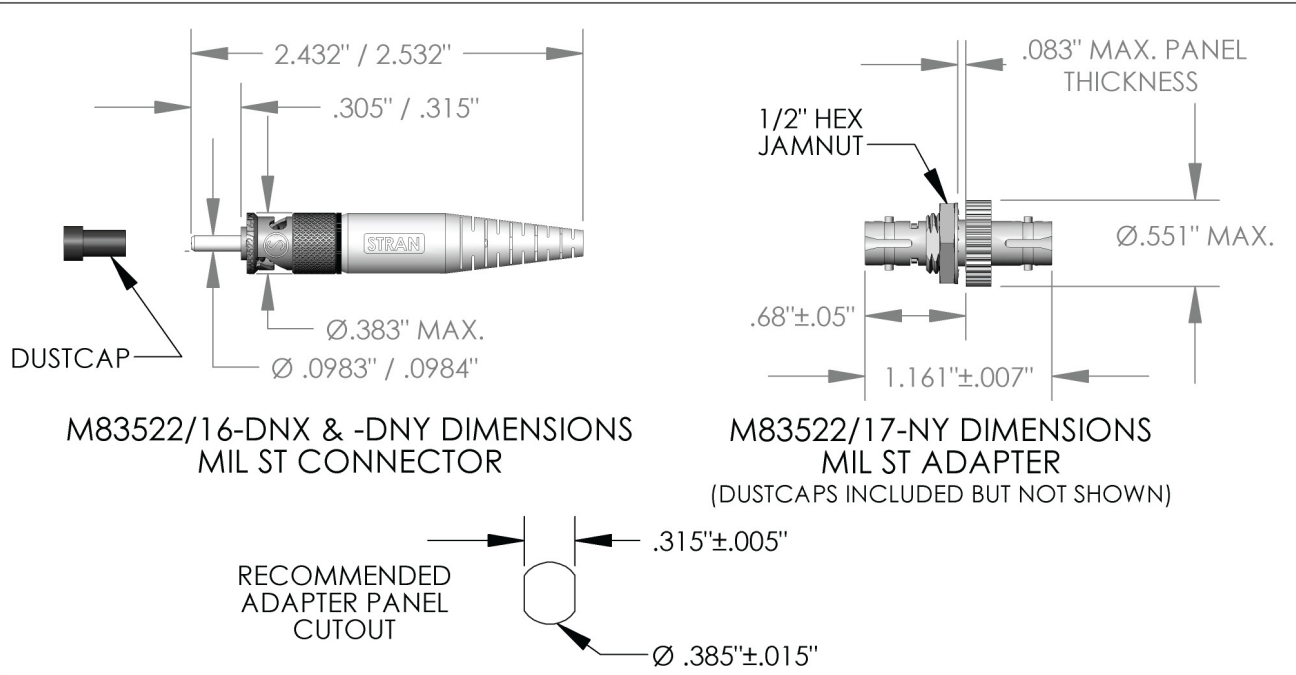

Optical Insertion Loss	9/125 μm: 1.00 dB _{max} , 0.46 dB _{typ} 62.5/125 μm: 1.00 dB _{max} , 0.20 dB _{typ}
Return Loss	>30 dB MMF, >45 dB SMF with PC polish
Mating Durability	>500 cycles per EIA-455-21
Vibration	MIL-STD-1344, Method 2005
Physical Shock	per MIL-S-901D, Grade A Type A Class 1
Thermal Shock	MIL-STD-1678, Method 4020
Temperature Cycle	-46°C to +85°C DOD-STD-1678 Method 4010
Salt Spray	MIL-STD-1344 Condition A Method 1001
Humidity	10 cycles, 65°C at 95% RH Method 4030 DOD-STD-1678
Operating Temperature	-55°C to +125°C
Dust	MIL-STD-202, Method 110
Flamability	MIL-STD-1344, Method 1012, Strain relief has UL94 V0 rating
Fungus Resistant	MIL-STD-810, Method 508
Weight	<20 grams