

General

This instruction sheet explains the procedures for installing and cabling the following types of Digital Signal Cross-Connect DSX-1/1C System panel assemblies:

- 800-Series
- 900-Series
- 900-NSD-Series
- Tie-circuit

CAUTION:

Sprays and cleaners can damage plastic parts. Do not apply any sprays or cleaners to this product that have not been specifically approved. Be especially careful not to expose any plastic parts to chemicals containing trichlorethane, which is often found in cleaning fluids and lubricant sprays.

CAUTION:

Do not attempt to loosen the screws that secure the front housing of the 800A-type connecting block to gain access to the jack contacts. Loosening these screws will cause the monitor circuit contacts inside the connecting block to release, rendering the block inoperative. See instruction sheet 365-301-120-4 for information on cleaning contacts.

Equipment Description

The panel assemblies consist of connecting blocks, a panel bracket that mounts the blocks, vertical designation labels, horizontal trough designation labels, wire retainers, designation strips and mounting hardware.

The panel assemblies covered in this instruction sheet are all mounted and cabled in a similar fashion. Any differences in procedure or special considerations for any particular panel type will be noted when they occur.

It is assumed that the following has been installed:

- All appropriate ED hardware groups—See ED-6C157-30 if further information is required.
- Cabling in the overhead racking.

WARNING:

Mounting more than two tie-circuit panels in any single bay frame will result in jumper congestion of the vertical troughs. Under no circumstances should this warning be ignored.

How to Contact Us

- To find out more about **Carrier Apparatus** products, visit us on the web at: <http://cw.commscope.com/>
- For technical assistance regarding Carrier Apparatus products: contact your local CommScope account representative or CommScope technical support at 1-800-344-0223.
- Report any missing or damaged parts to CommScope customer service in Omaha, Nebraska, at 1-866-539-2795.

References

- 365-301-120, *800-Series and 900-Series DSX-1/1C Systems, System Reference Guide*
- 365-301-120-3, *800-Series and 900-Series DSX-1/1C 800A-Type Connecting Block Installation, Removal and Cleaning*
- 365-301-120-12, *800-Series and 900-Series DSX-1/1C DIXI-Type Connecting Block Installation, Removal and Cleaning*
- Schematic Drawing SD-97807-01
- ED-6C150-10, *Engineering and Layout of the 800-Series DSX*
- ED-6C150-11, *Engineering and Layout of the 900-Series DSX*
- ED-6C150-12, *Enhanced 900-Series DSX-1/1C Typical Equipment Layout*
- ED-6C152-32, *Enhanced 900-Series DSX-1/1C Framework Ordering Groups*
- *Installation Engineering Handbook 9—Section 129.1, 900-Series DSX—Digital System Cross-Connect Frame*

Tools Required

- Cable stripper
- Spudger
- Screw-starter
- Wire stripper
- Cable ties and/or lacing cord
- Flat-blade 0.25-inch (6 mm) wide screwdriver, 6 inches (152 mm) long
- Wire-wrap gun with 5-inch (127 mm) extension bit

Ordering Information

Apparatus Code	Material ID	Description
900G3-E2-NSD	106 772 635	Connecting block, 900G3-E2-NSD
900G3-E1-NSD	106 772 627	Connecting block, 900G3-E1-NSD
900G3-C1-NSD	106 826 530	Connecting block, 900G3-C1-NSD
900G3-A1-NSD	106 772 619	Connecting block, 900G1-A1-NSD

PANEL MOUNTING BRACKET INSTALLATION

The following procedures describe how to mount the panel mounting bracket to the Network Bay Frame for the 800-type panel and the 900-type panel. Refer to Figure 1 to install 800-type panels, and Figure 2 on page 4 to install mounting brackets on 900-type or 900-NSD-type panels.

1. Locate the mounting position on wide flange side of bay frame and loosely secure panel mounting bracket with screws provided. Use four No. 12-24 screws, two on each side.
2. Mount vertical troughs with two No. 12-24 screws each and tighten all screws.

NOTE:

For 900-Series DSX applications, vertical troughs are supplied separately as part of ED-6C152-31. For 900-Series NSD applications, the vertical troughs are supplied as a part of ED-6C157-30 and ED-6C157-31. For 800-Series DSX, the troughs come with the 800G-type panels.

3. Slip the vertical designation label and clear label cover into the vertical troughs (see Figure 1, Figure 2, and Figure 3 on page 4).

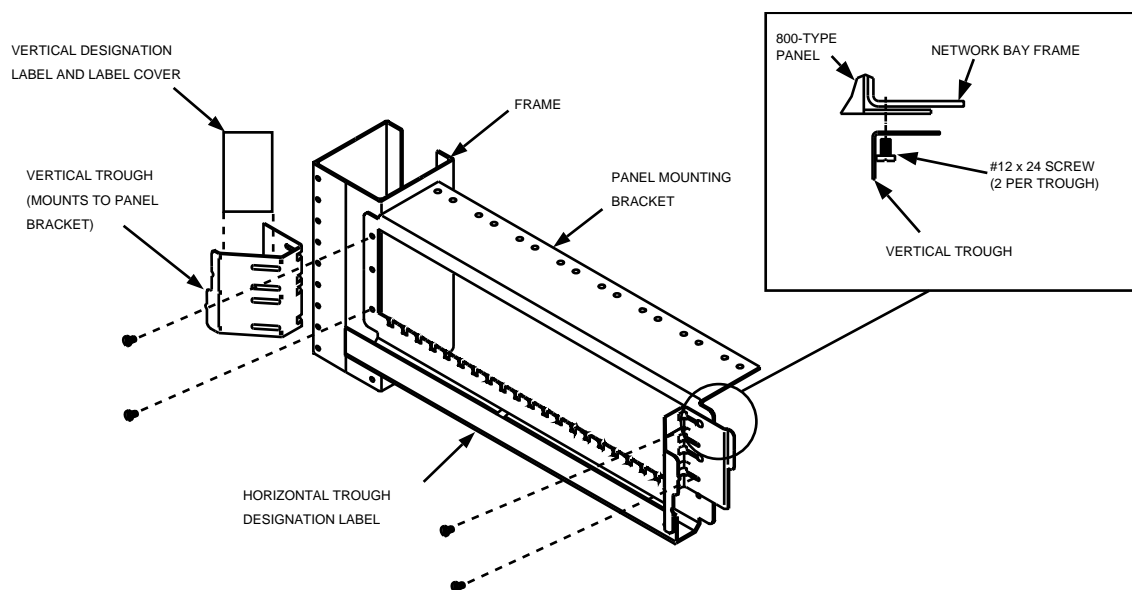

Figure 1. 800-Type Panel

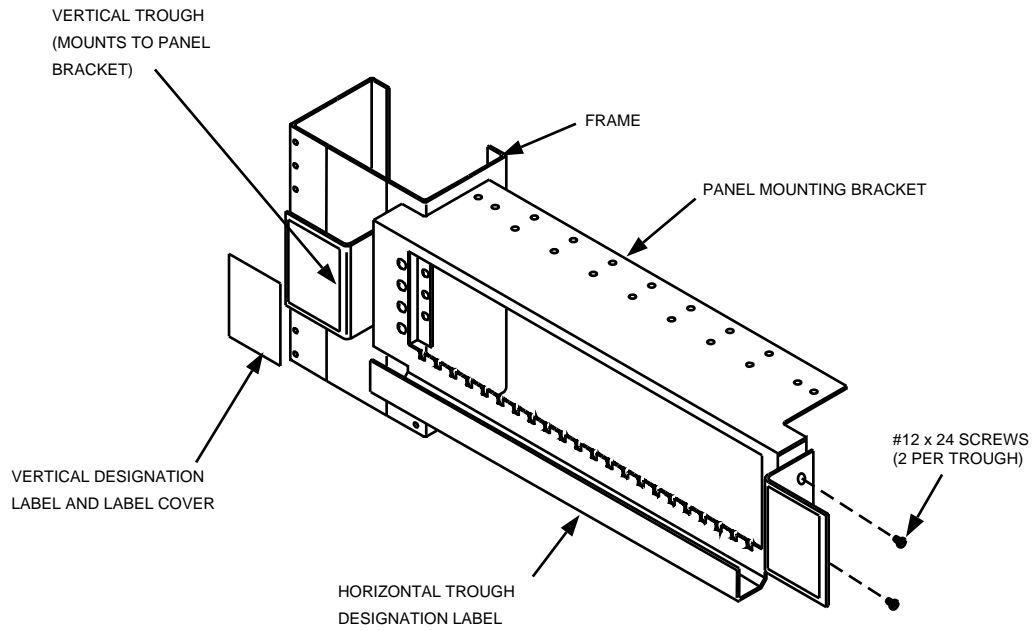

Figure 2. 900-Type Panel

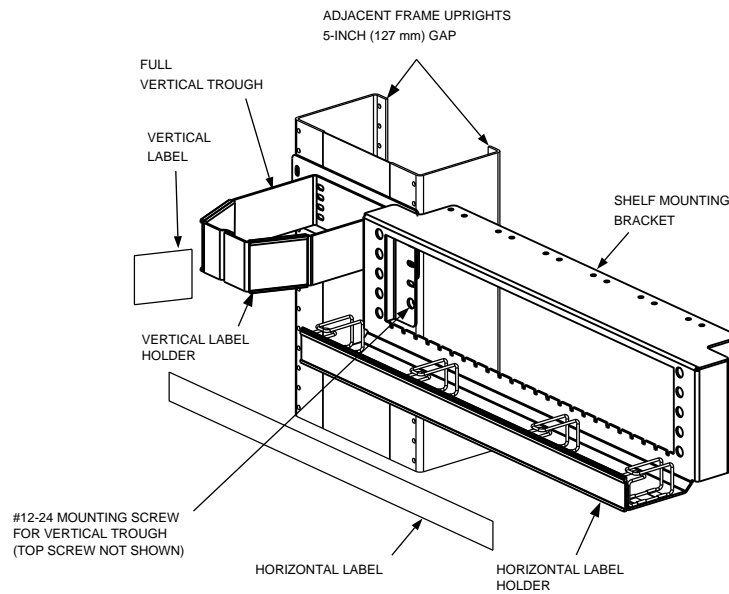

Figure 3. 900-NSD Type Panel

ROUTE PANEL CABLES

Refer to the following procedures and to Figure 4 to route panel cables. The figure shows the cabling in slot position 8, as appropriate for mounting bracket in panel position 8, where panel position 1 begins at the bottom of the frame.

1. Route cable into proper slot of the cable retaining bracket associated with the panel mounting bracket position.
2. Butt and strip cable 1/2-inch (13 mm) below retaining bracket, allowing for conductors a minimum of 36 inches (900 mm) in length.
3. Secure cables with twine or nylon ties to the retaining bracket.
4. Partition conductors to each block position and secure to the panel mounting bracket using twine or wire ties.
5. Cut remaining conductor length to 12 to 15 inches (300 mm to 380 mm) from secured position on panel mounting bracket.

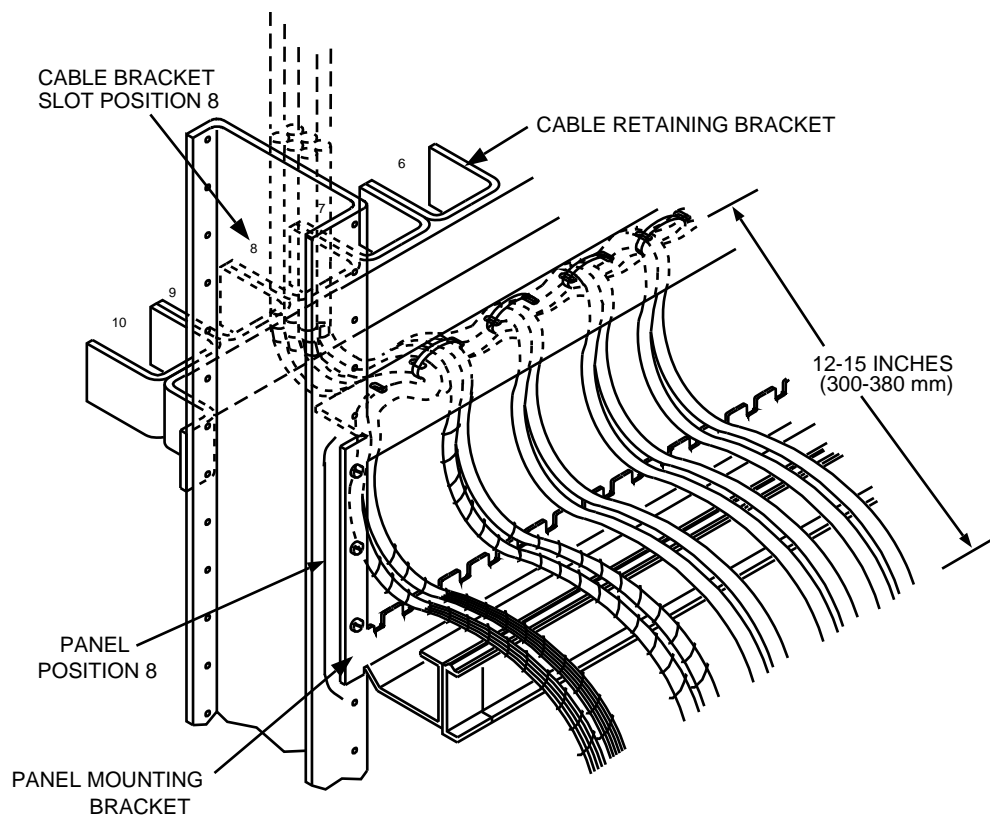

Figure 4. Routing Panel Cables

TEMPORARILY SECURE CONNECTING BLOCK TO SHELF

1. Temporarily suspend the connecting block on the panel mounting bracket with cabling side facing out and ready for wire-wrap termination (see Figure 5). When hung in this position, the circuit identification on the rear of the block is "upside-up" to aid in wiring operations.
2. Temporarily secure blocks to bracket with lacing cord during cabling operation (not shown in Figure 5).

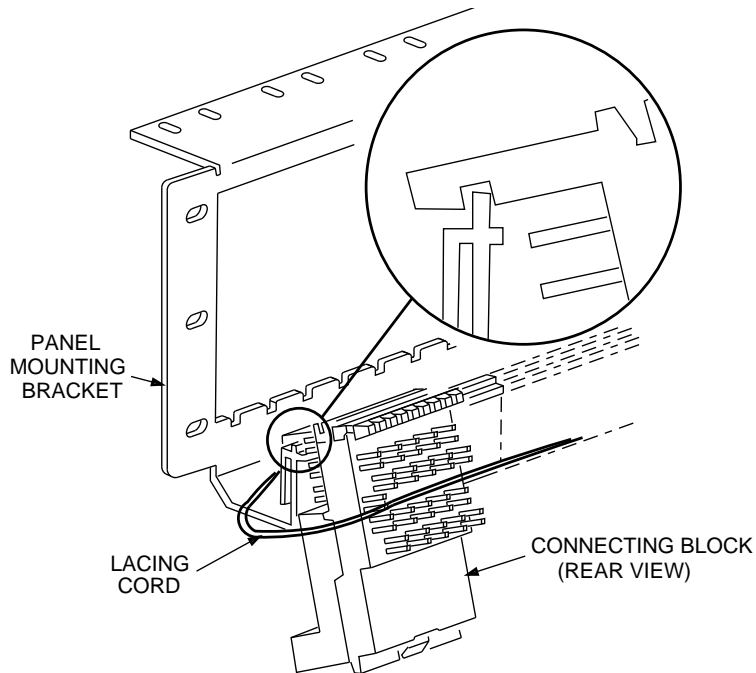

Figure 5. Temporarily Secure Connecting Block to Shelf

INSTALL CONNECTING BLOCK WIRING

1. Pull free end of formed cable legs and dress conductors over fanning strip and down across the back of the block (see Figure 6).
2. Strip conductors and wire-wrap them to corresponding terminals. Transmit circuits are terminated on the output cable pins, and receive circuits are terminated on the input cable pins.

CAUTION:

Do not attempt to push or pull the wire-wrap pins into, or out of, the rigid backplane of the connecting block. These pins are soldered to a flexible printed circuit board, and applying excessive force can damage either the flexible board or the solder joint. Follow all applicable industry standard wire-wrapping techniques.*

3. Dress terminated conductors by snapping them through slotted fanning strip.

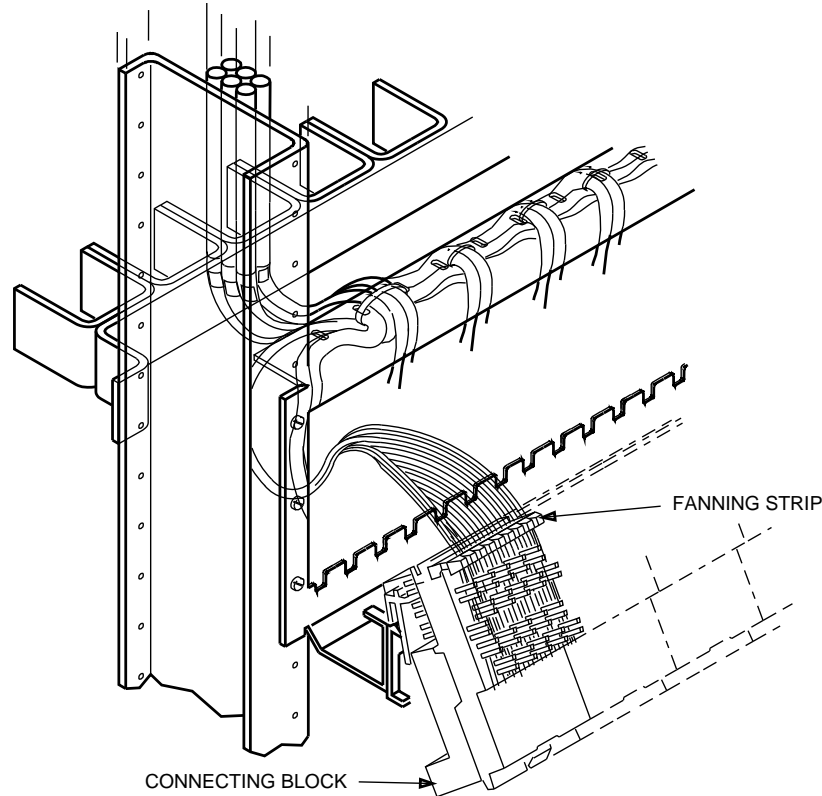

Figure 6. Install Connecting Block Wiring

* For information about wire-wrapping techniques, see Lucent Practice 800-612-154, or ANSI/EIA Standard RS-280-B.

INSTALL BATTERY AND GROUND LEADS (800A-TYPE BLOCKS ONLY)

1. Route ground and power leads from fuse panel to first block position and terminate on pins labeled GRD and -48 V (see Figure 7). These pins are longer than the input and output pins to allow multiple wire-wraps. Observe the Caution on the previous page.
2. Connect power and ground leads on each of the blocks by "daisy chaining" one block to the next. Leave 12 inches (300 mm) of slack between each block position.

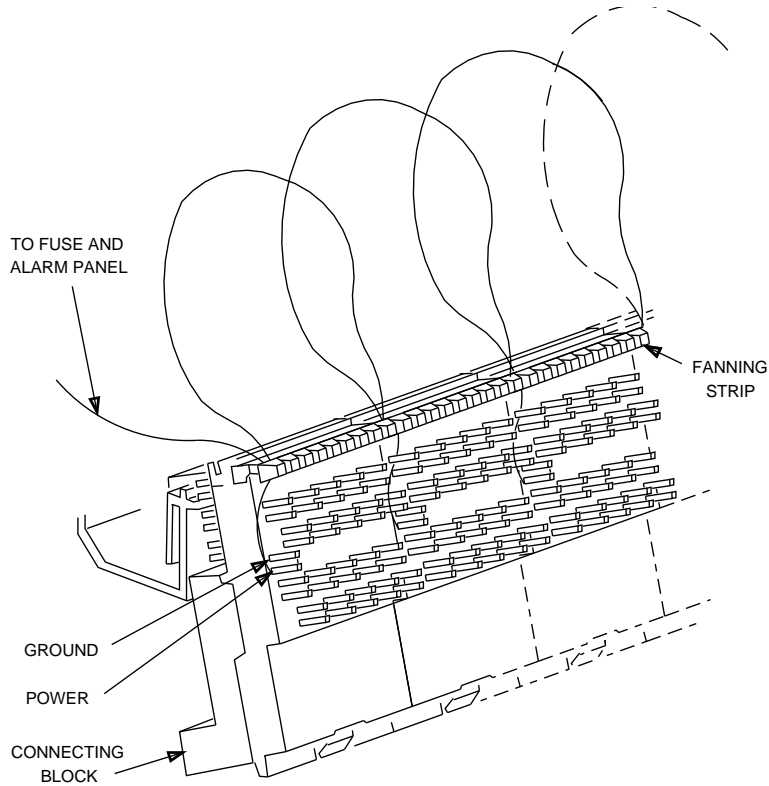

Figure 7. Install Battery and Ground Leads

FORM CABLE AND INSTALL BLOCKS

1. Cut the lacing cord securing blocks to panel.
2. Form cable slack and secure (see Figure 8). Leaving cable slack simplifies any future connecting block removal or replacement procedures that may be necessary.
3. Lift and rotate each block upward placing slot at bottom of fanning strip onto sawtooth ledge of mounting bracket.
4. Push block into opening of bracket until latch on block snap-locks into bracket.
5. Verify all blocks are properly secured into panel bracket by grasping each block at top and pulling from front with a moderate force of approximately 10 lb. (4.5 kg).

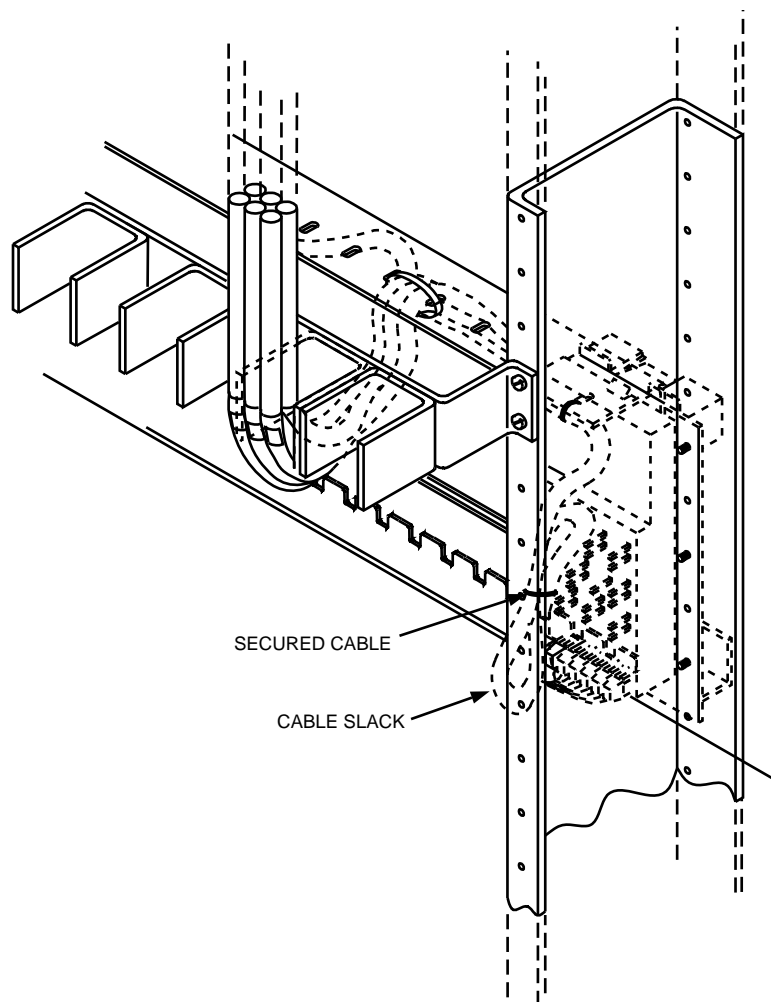

Figure 8. Form Cable and Install Blocks

APPLY CIRCUIT IDENTIFICATION LABEL TO BLOCK FACE—(800A-TYPE BLOCKS ONLY)

Apply circuit labels to the front face of each connecting block, covering the four screws exposed on the block. Apply circuit label 1–10 to the first (left-most) connecting block on the shelf, 11–20 on the second block, etc. (see Figure 9).

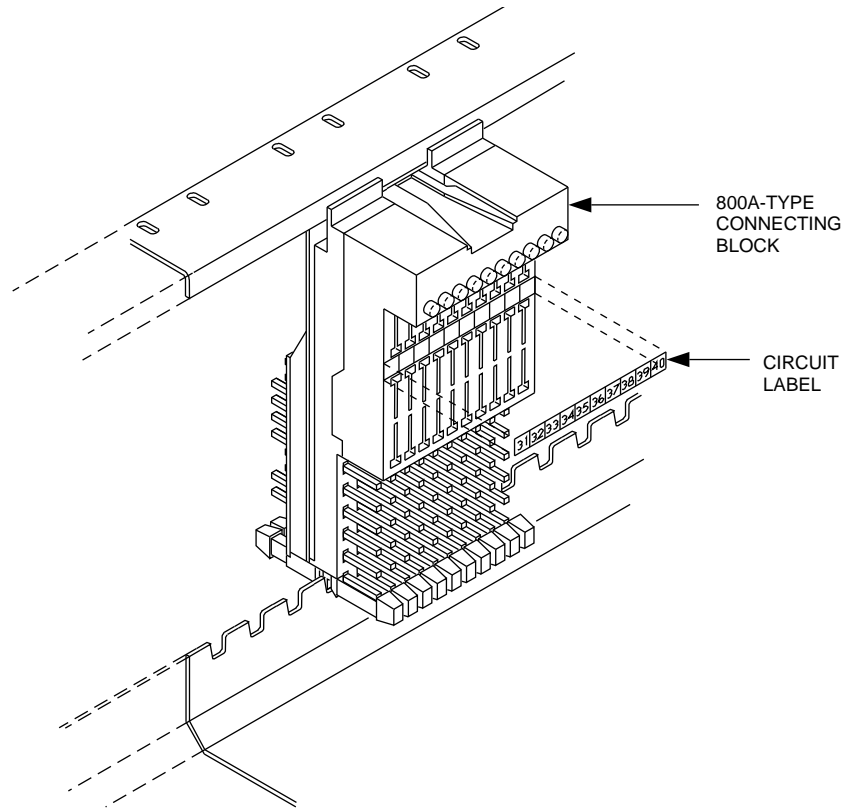

Figure 9. Apply Circuit Identification Label To Block Face

CONTINUITY TEST FOR BLOCKS AND CABLING

There are several ways to test blocks and cabling for continuity. The method described here is only one of several alternatives. Although Figure 10 shows an 800A-type connecting block, this method can be used with the 800B-type connecting blocks.

➤ NOTE:

The 800 K2/0 (Material ID 105 757 926) plug is a "loopback" plug that can be used for the following test instead of jumper wire in Steps 1 and 2 below.

At the near end (front) of connecting block in wire-wrap pin field:

1. Temporarily loop T(OUT) of a circuit to T(IN) of the same circuit using 6-inch (152 mm) length of 24-gauge (0.5 mm) wire.
2. Repeat above step with R(OUT) and R(IN).
3. Repeat above two steps for each of the circuits of the block.

At the far end (equipment side) of cross-connection, measured at cable:

4. Test continuity on the cable between T(IN) and T(OUT) for each of the ten circuits of the block.
5. When continuity has been verified in all ten circuits, remove temporary 6-inch (152 mm) loops or the 800 K2/0 plug, if used.
6. If continuity test fails, check for tip and ring reversal and wire-wrap quality. If continuity is still not present, perform cleaning procedure as outlined in instruction sheet 365-301-120-3 and test continuity again.

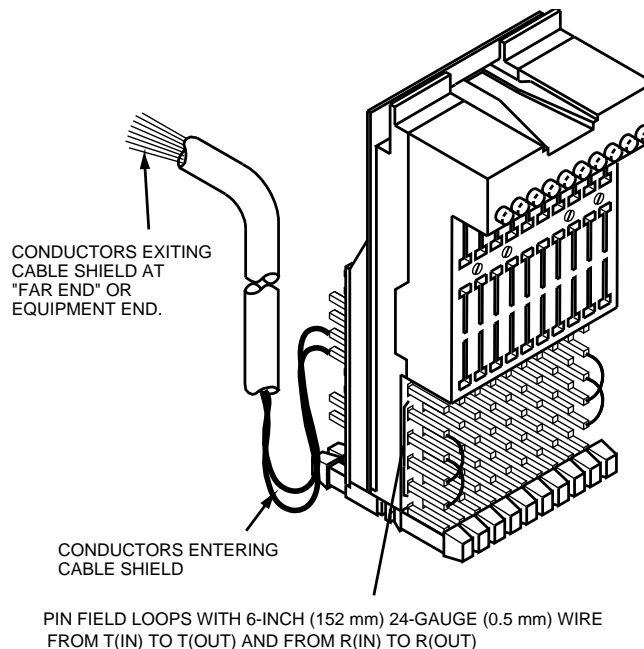

Figure 10. Test Continuity of Blocks and Cabling

MEGALINK PANEL INSTALLATION—TIE-CIRCUIT PANEL

When installing an 800G2-E4 panel follow these steps to attach the protective cover assembly, after the panel assembly is mounted to the frame (see Figure 11):

1. Mount stand-off (2) to the top hole position of the MEGALINK panel.
2. Assemble nut (4) onto the longer end of item number 3. Allow for a minimum of five threads of item number 3 to be exposed.
3. Position item number 3 so that the shorter end points straight up.
4. Tighten nut (4) so that item 3 stays in the up position.
5. Repeat for second stand-off assembly.
6. Place each long slot in cover (1) over short end of item 3.
7. Attach cap nut (5) to short end of item 3. The cover is now captivated and may be positioned in the down (covered) position or up (open) position. Cover (1) rests on stand-offs (2) in the open position.

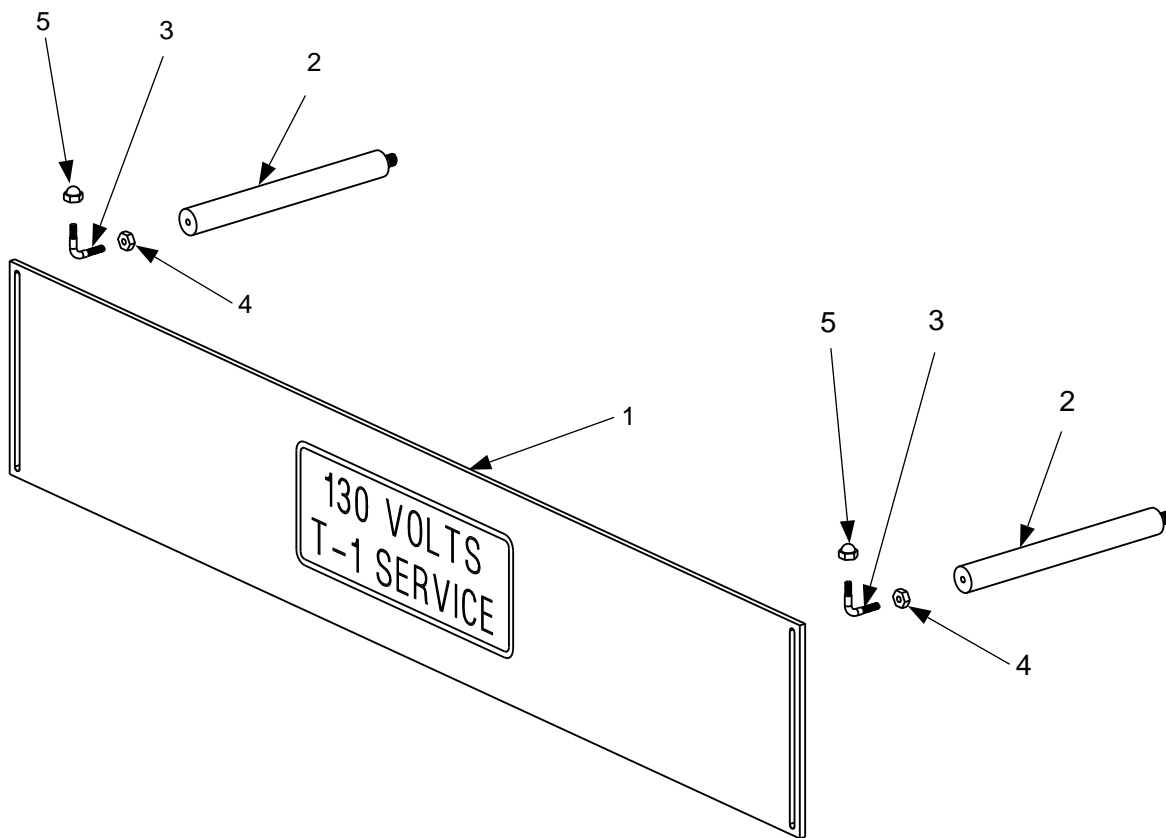

Figure 11. MEGALINK Panel Installation—Tie-Circuit Panel

MOUNTING THE 900G3-E1 (OR E2) TIE-CIRCUIT PANEL

1. Determine mounting location by placing 0.5-inch (13 mm) clearance holes (two on each side) of mounting bracket over mounting screws of full vertical trough.
2. Secure mounting bracket with four No. 12-24 screws (see Figure 12).

INSTALLING LABEL HOLDERS ON 900G3-E1 (OR E2) PANEL

1. Install vertical label into label holder by sliding label into holder.
2. Install horizontal label by sliding label in end of designation strip.
3. Slide clear cover over horizontal label for protection.

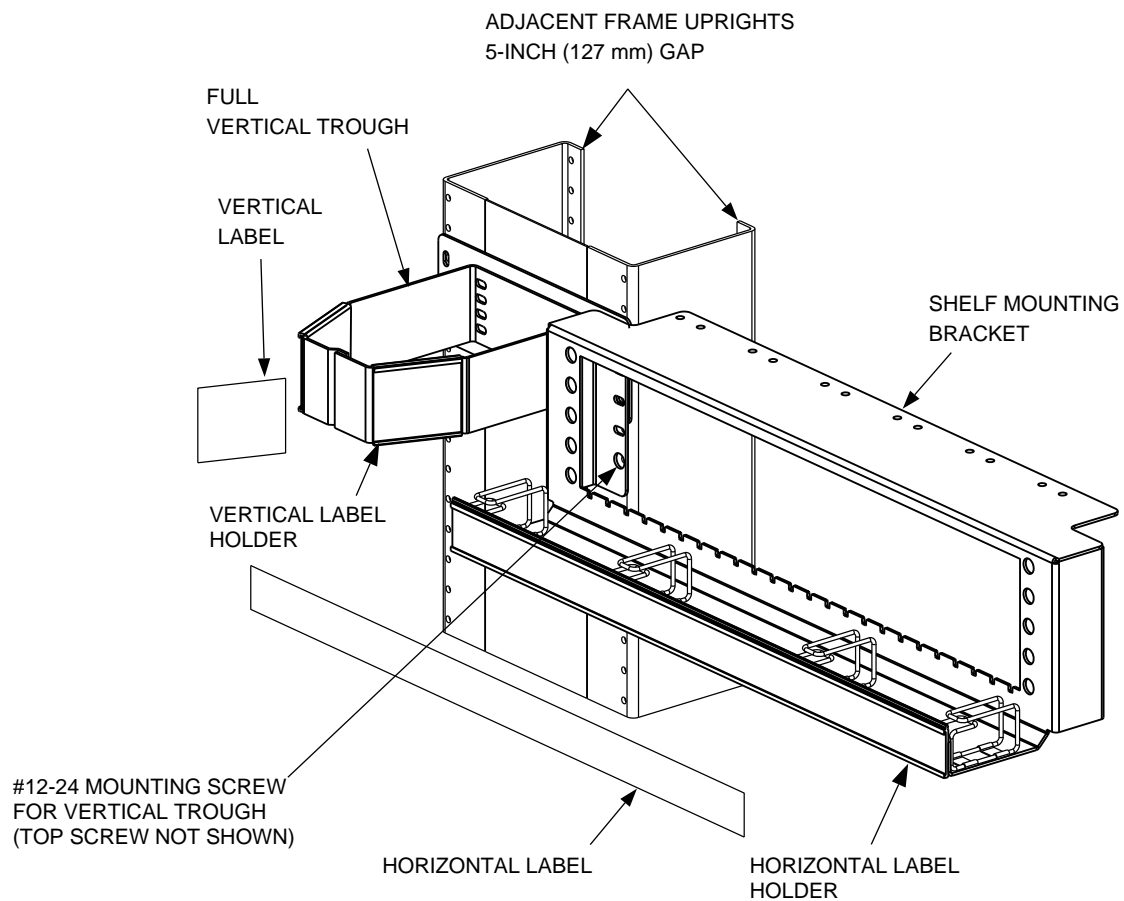

Figure 12. 900G3-E1 (or E2) Tie-Circuit Panel Hardware Installation