

General

The Digital Systems Access Bays (DSABs) are robust intermediary termination points between Digital Cross-Connect Systems (DCSs) and various network elements. Digital Systems Access Bays provide a convenient termination point for dissimilar cables (pair count, gauge, insulation, etc.) in a location that is removed from the backplane of the DCS Interface Bays. Connections on the backplane of the DCS Interface Bay may be directly cabled to the DSAB at the time of installation and left permanently in place. Future installations, removals, and rearrangements can be performed directly at the DSAB, away from sensitive DCS backplanes. The three DSABs are designed to match the cabling complements and density of the DACS III-2000 and the DACS IV-2000 Interface Bays. The DSAB1 is designed to match the DACS IV-2000 DS1, the DSAB3/1 to match the DACS IV-2000 DS3, and the DSAB3/3 to match the DACS III-2000 DS3 Interface Bays.

Equipment Description

This instruction sheet covers equipment installation for the Digital Systems Access Bay panels 3/1 and 3/3 (DSAB3/1 and DSAB3/3).

The DSAB3/1 panel is intended for use with the DS3 Interface Bay of the DACS IV-2000. The DSAB3/1 bay contains up to eight panels; each consists of 31 DS3 terminations for a total of 248 terminations. These correspond to four 62-circuit DACS IV-2000 DS3 Interface Bays or a combination of two 62-circuit DS3 Interface Bays and four 46-circuit DS3/DS1 Interface Bays. A single DSAB3/1 bay is sufficient to cable an entire set of DACS IV-2000 DS3 circuits.

The DSAB3/3 panel is intended for use with the DS3 Interface Modules of the DACS III-2000. The DSAB3/3 bay contains up to ten panels; each consists of 24 DS3 terminations for a total of 240 terminations. These correspond to one set of DACS III-2000 DS3 (IN) and DS3 (OUT) Interface Modules. A total of eight bays are required for the maximum configuration of the DACS III-2000 (2048) System.

How to Contact Us

- To find out more about **Carrier Apparatus** products, visit us on the web at: <http://cw.commscope.com/>
- For technical assistance regarding Carrier Apparatus products: contact your local CommScope account representative or CommScope technical support at 1-800-344-0223.
- Report any missing or damaged parts to CommScope customer service in Omaha, Nebraska, at 1-866-539-2795.

References

- 365-301-135 — *Digital Systems Access Bays, Installation and Operation Reference Guide*
- ED-6C174-31 — *DSAB3/1 Common System Specifications*
- ED-6C174-30 — *DSAB3/3 Common System Specifications*
- ED-6C174-11 — *DSAB3/1, Method of Cabling*
- ED-6C174-12 — *DSAB3/3, Method of Cabling*

ORDERING INFORMATION

The table below lists the individual components that comprise the ED6C174-31, Group 1 (Material ID 601 336 878) Ordering Group, which is the DSAB3/1 panel configuration.

Description	Quantity
31-circuit access panel	1
Filler panel, 2 inch (51 mm) high	1
Transition trough	1
Cable bracket, 5 inch (127 mm)	1
Label (31-circuit panel DACS)	1
Label (31-circuit panel EQUIPMENT)	1
Label covers*	2
Tie bar	1
Screws, PHM 12-24	20
Cable straps*	2
Instruction sheet	1
* Not shown in Figure 1	
Note: Group 3 deleted after first office application	

STEP 1— CHECK CONTENTS AGAINST PARTS LIST OF GROUP 1 (DSAB3/1)

Refer to Figure 1.

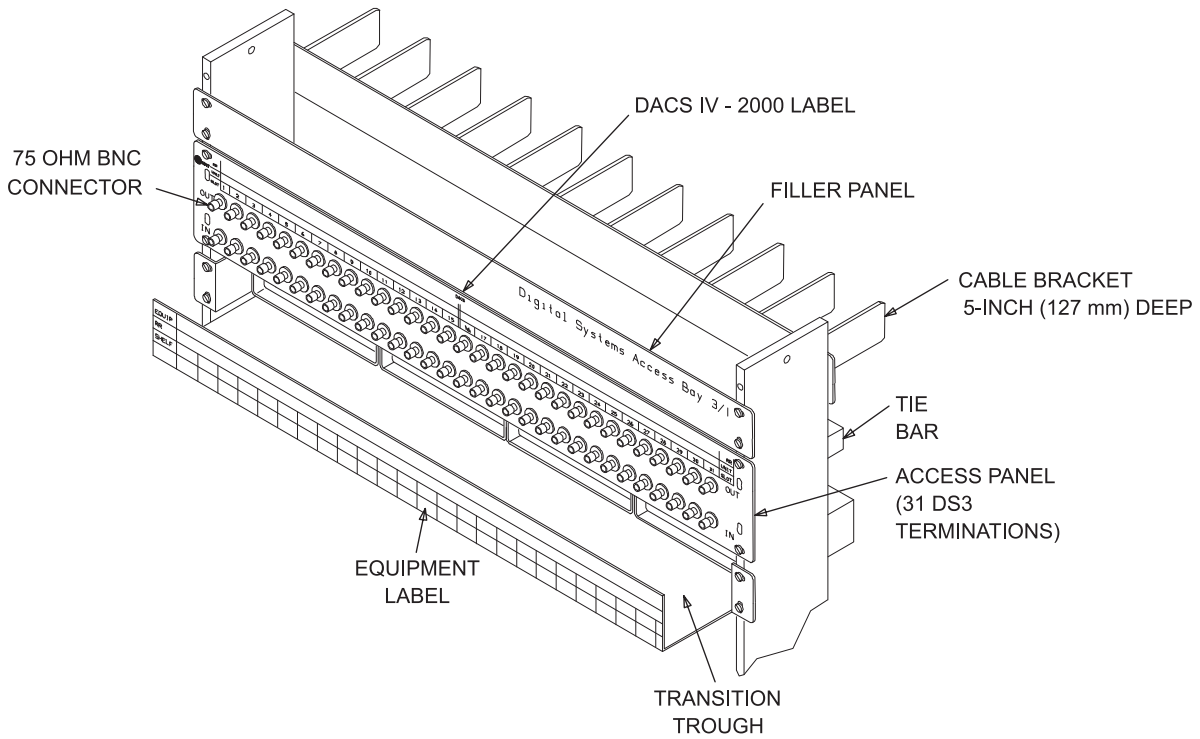

Figure 1. DSAB3/1 Assembly Components (Group 1)

ORDERING INFORMATION

Table 1 lists the individual components that comprise the ED6C174-30 Group 1 (Material ID 601 336 829), Group 2 (Material ID 601 336 837), and Group 4 (Material ID 601 336 860) Ordering Groups, which are the DSAB3/3 panel and bay configurations.

Table 1: Individual Components for Groups 1, 2, and 4

Description	Quantity
Group 1 (Material ID 601 336 829)	
24-circuit access panel	1
Filler panel, 2 inch (51 mm) high	1
Transition trough	1
Cable bracket, 5 inch (127 mm)	1
Label (24-circuit panel DACS)	1
Label (24-circuit panel EQUIPMENT)	1
Label covers*	2
Tie bar	1
Screws, PHM 12-24	20
Cable straps*	2
Instruction sheet	1
Group 2 (Material ID 601 336 837)	
24-circuit access panel	10
Filler panel, 2 inch (51 mm) high	10
Transition trough	10
Cable bracket, 5 inch (127 mm)	12
Labels (24-circuit panel DACS)	1
Labels (24-circuit panel EQUIPMENT)	10
Label covers*	20
Tie bars	10
Screws, PHM 12-24	204
Cable straps*	20
Instruction sheet	1
Group 4 (Material ID 601 336 860)	
24-circuit access panel	1
Label (24-circuit panel DACS)	1
Label cover*	1
Screws, PHM 12-24	4
Instruction sheet	1
* Not shown in Figure 2 on page 4 or Figure 3 on page 5. Note: Group 3 deleted after first office application.	

STEP 1—CHECK CONTENTS AGAINST PARTS LIST OF GROUP 1 (DSAB3/3)

Refer to Figure 2.

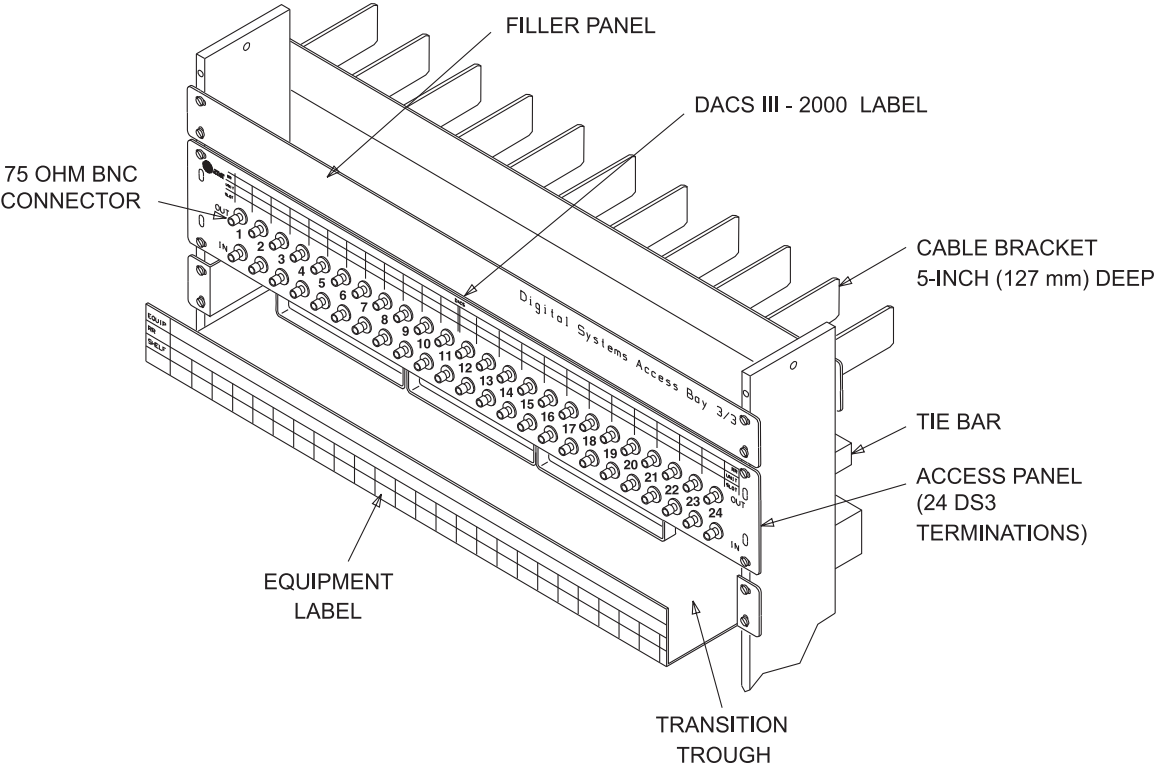

Figure 2. DSAB3/3 Assembly Components (Group 1)

STEP 1—CHECK CONTENTS AGAINST PARTS LIST OF GROUP 2 (DSAB3/3)

Refer to Figure 3.

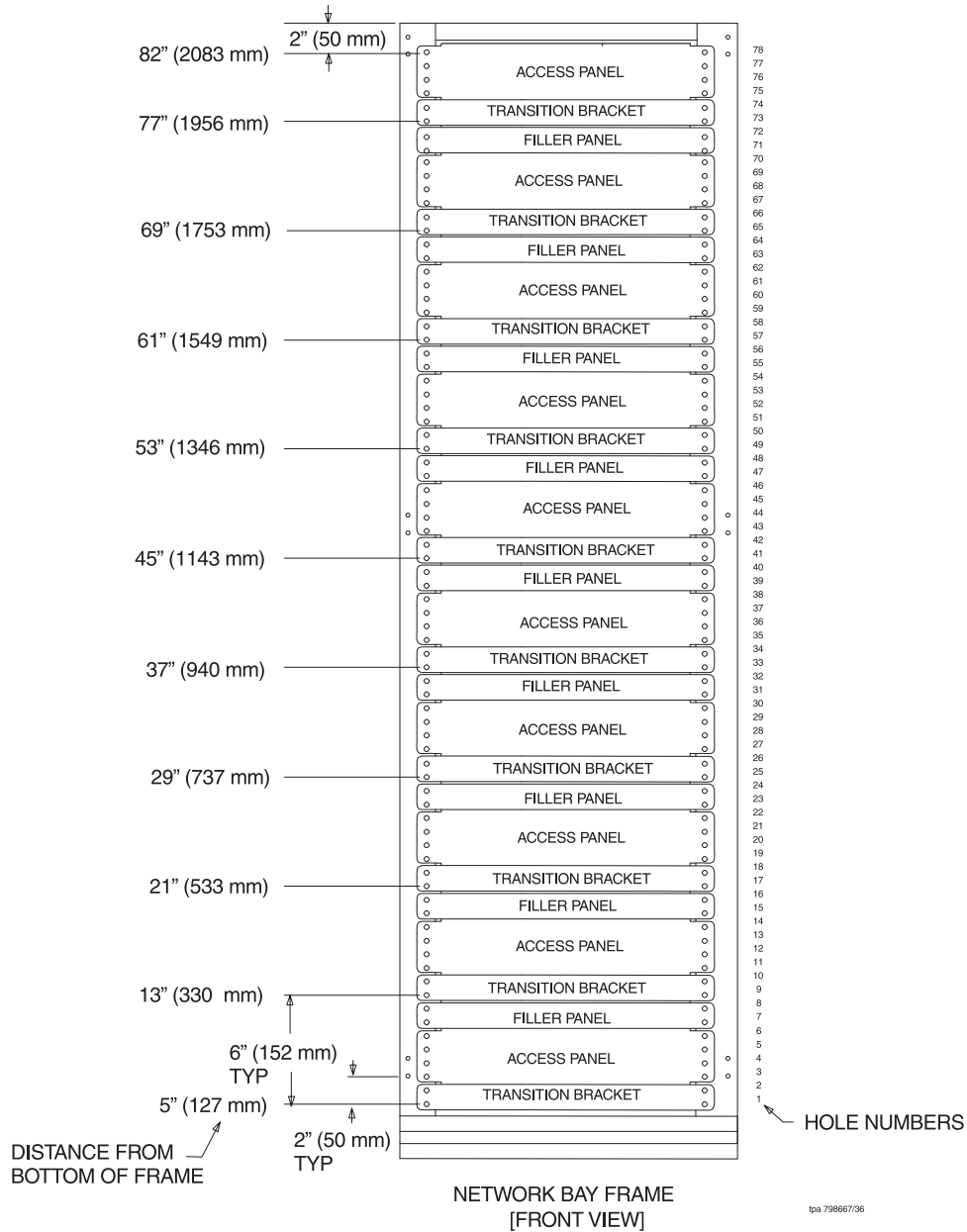

Figure 3. DSAB3/3 Assembly Components (Group 2)

ORDERING INFORMATION

Table 2 lists the separately orderable piece parts available for the DSAB3/1 and DSAB3/3.

Table 2: Separately Orderable Piece Parts

Apparatus Code	Material ID	Description	Quantity
DSAB CB2	106 641 293	Cable bracket, 2 inch (51 mm)	1
DSABLP1-BNC	106 657 588	Loopback plug-push on	1
BNC BH	106 641 301	Isolated BNC-to-BNC bulkhead connector	1

Also available is a rear cable cover (Material ID 845 373 497) for use when cables are routed from underneath and a package of 20 terminal punching (Material ID 845 601 772) for use with cable sheath ground wires.

STEP 2—MOUNT DSAB3/1 OR DSAB3/3 PANEL ASSEMBLIES

1. Locate the mounting positions on the network bay frame for the number of shelves to be mounted. Refer to Figures 4 or 5. Shelf assemblies are mounted in the bay starting at the lowest shelf assembly first, then working up the bay.
2. When mounting Group 2, begin with the transition trough, using four 12-24 screws. When mounting individual panels, be sure to position them according to the projected final bay layout shown in Figure 4 on page 8 or Figure 5 on page 9.
3. Mount the access panel directly above the transition trough, using four 12-24 screws.
4. With the exception of the top (10th) panel in the DSAB3/3 when mounted in a 7-foot (2.1 m) bay, mount the filler panel above the access panel assembly, using the four 12-24 screws. In the case just described, the extra filler panel should be discarded.
5. Repeat Items 2 through 4 for the remainder of the shelf assemblies to be installed in the bay.
6. Slip the equipment designation label and the clear label cover into the plastic retaining slot on the transition shelf. This label may be removed and marked later when you are ready to identify the circuits.
7. Slip the DACS label and its cover into the plastic retaining slot on the filler panel.
8. At the rear of the bay, install one cable bracket directly behind each filler panel installed on the front of the frame, using four 12-24 screws. In accordance with Figures 4 and 5, the cable bracket for the uppermost shelf assembly should be positioned in hole No. 74 for DSAB3/1 and hole No. 78 for DSAB3/3. ED6C174-31, Group 2 for DSAB3/1 and ED6C174-30, Group 2 for DSAB3/3 includes two additional cable brackets. When a 7-foot (2.1 m) frame is used, one additional cable bracket should be installed at the top of the bay, in position 78, and the second bracket may be discarded. When a 9-foot (2.7 m) or 11-foot 6-inch (3.5 m) bay is used, one cable bracket should be installed at the top of the bay in the uppermost hole and the second cable bracket should be mounted halfway between the top of the bay and the highest shelf assembly. This would be reversed for subfloor cabling.
9. Mount one tie bar for DACS cables on the rear of the bay directly opposite the second hole from the top of the access panel for each panel installed, using two 12-24 screws.

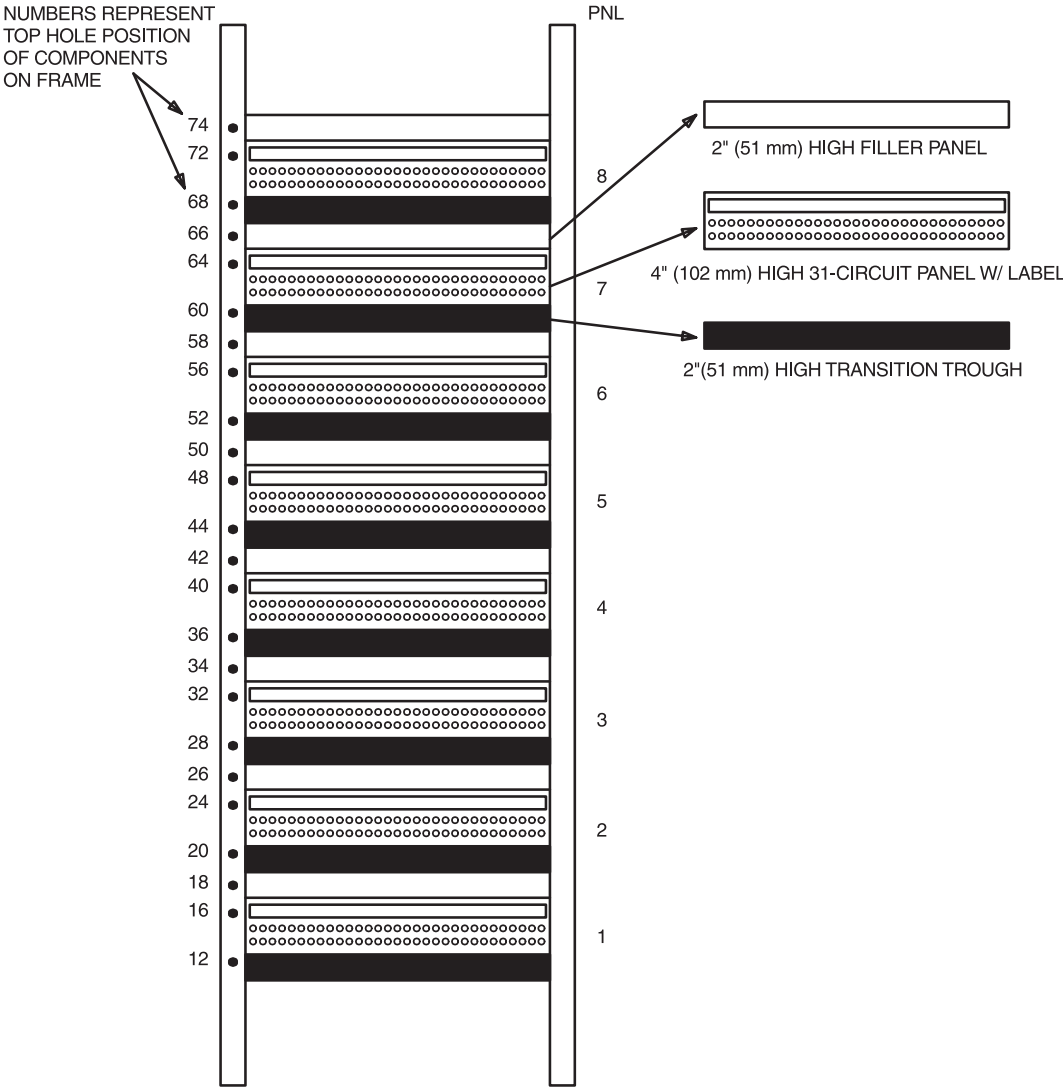

Figure 4. DSAB3/1 Spacing of Assembly Components

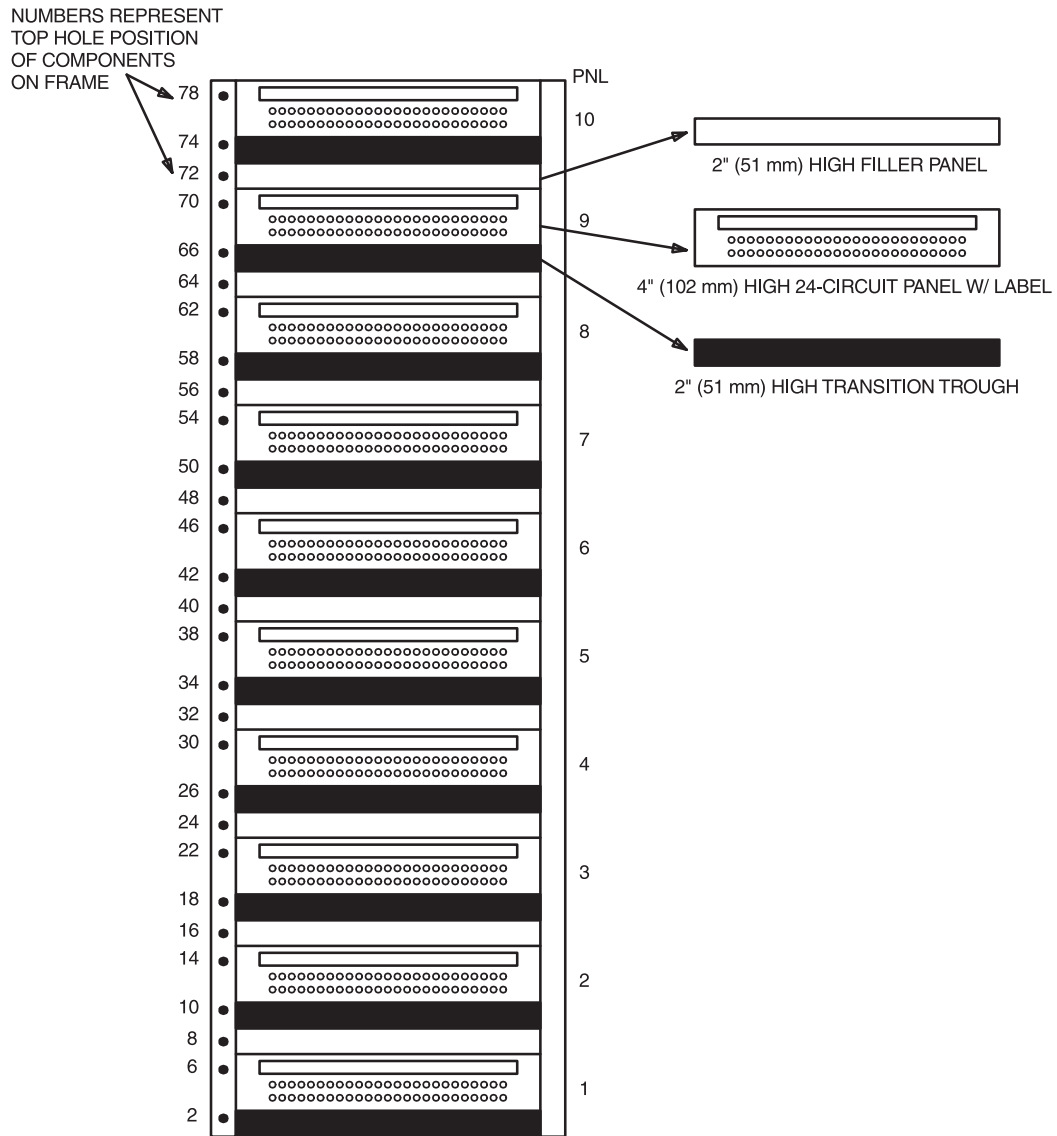

Figure 5. DSAB3/3 Spacing of Assembly Components

STEP 3—ROUTE DACS AND EQUIPMENT CABLES ON DSAB3/1 AND DSAB3/3

NOTE:

The DSAB3/1 or DSAB3/3 Systems are usually cabled with a standard 5-inch (127 mm) deep cable retainer bracket on the rear of the frame for equipment cable. A 2-inch (51 mm) cable retainer bracket is available when a 12-inch (305 mm) footprint is required. **A 734 or smaller cable is strongly recommended for this application.**

1. Mount a cable strap between adjacent bays two holes below the bottom of each cable retaining bracket. See Figure 6 on page 11.
2. Route the DACS cables down between the bays allowing for approximately 36 inches (0.9 m) of length beyond the uppermost hole of the associated access panel. The cable coming from the DACS (OUT) should be routed on the left side of the bay as viewed from the rear. The cable going to the DACS (IN) should be routed on the right side of the bay as viewed from the rear.
3. Tie the cables to the cable straps to assist in pulling the cable into the gap between the bays.
4. Cut the DACS cable to the appropriate length to ensure enough slack in the vertical space between network bay frame for future rearrangement. Terminate cable with a BNC connector, following the instructions included with the connector.
5. Route the DACS (IN/OUT) cable to the associated (IN/OUT) connectors on the rear of the access panel and connect the cables.
6. Secure the cables (installed in Item 2) to the tie bar using twine or nylon ties.

NOTE:

If KS-19224, L2 minicoaxial is used for DACS cabling, fiber must be used when cable tie(s) are used to bound tightly.

7. Route the equipment cables into the proper slots of the cable retaining brackets. For overhead cabling, the lowest shelf installed should have the longest cable routed in the outermost slot on the left side of the frame as viewed from the rear. The next lowest shelf installed should have the next longest cable routed in the outermost slot on the right side of the frame as viewed from the rear. The third lowest shelf cables are routed on the left side in the slot next to the outermost slot. The fourth shelf cables are routed on the right side in the slot next to the outermost slot on the right. Continue this pattern for the remaining shelves to be installed. This will leave the shortest cables in the center providing the most access to all shelves. Refer to Figure 7 on page 12 and Figure 8 on page 13.
8. Secure the cables to all of the retaining brackets except the one at the rear of the panel that the cable is being formed through, using twine or nylon ties.
9. Cut equipment cables off approximately 40 inches (1.0 m) beyond the point at which they pass through their intended cable bracket. Connectorize the equipment cable with a BNC connector, following the instructions included with the connector.
10. Route the equipment cables through the associated transition trough brackets to the front of the access panel and connect the equipment cable to the associated connector on the access panel.
11. Dress slack and secure cable to final retaining bracket.

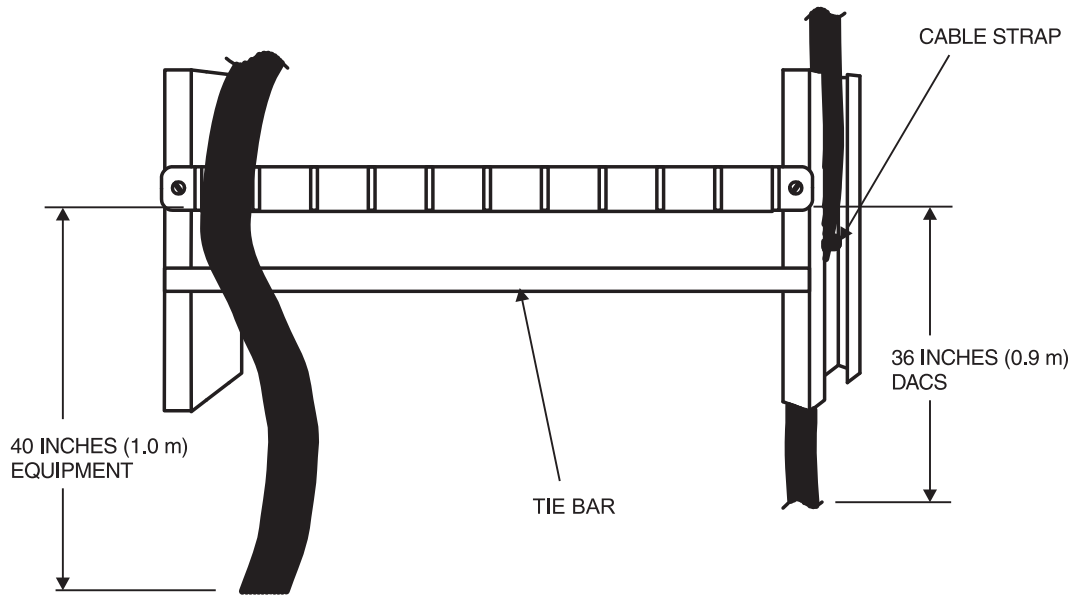

Figure 6. DSAB3/1 and DSAB3/3 Cable Cut-off Length

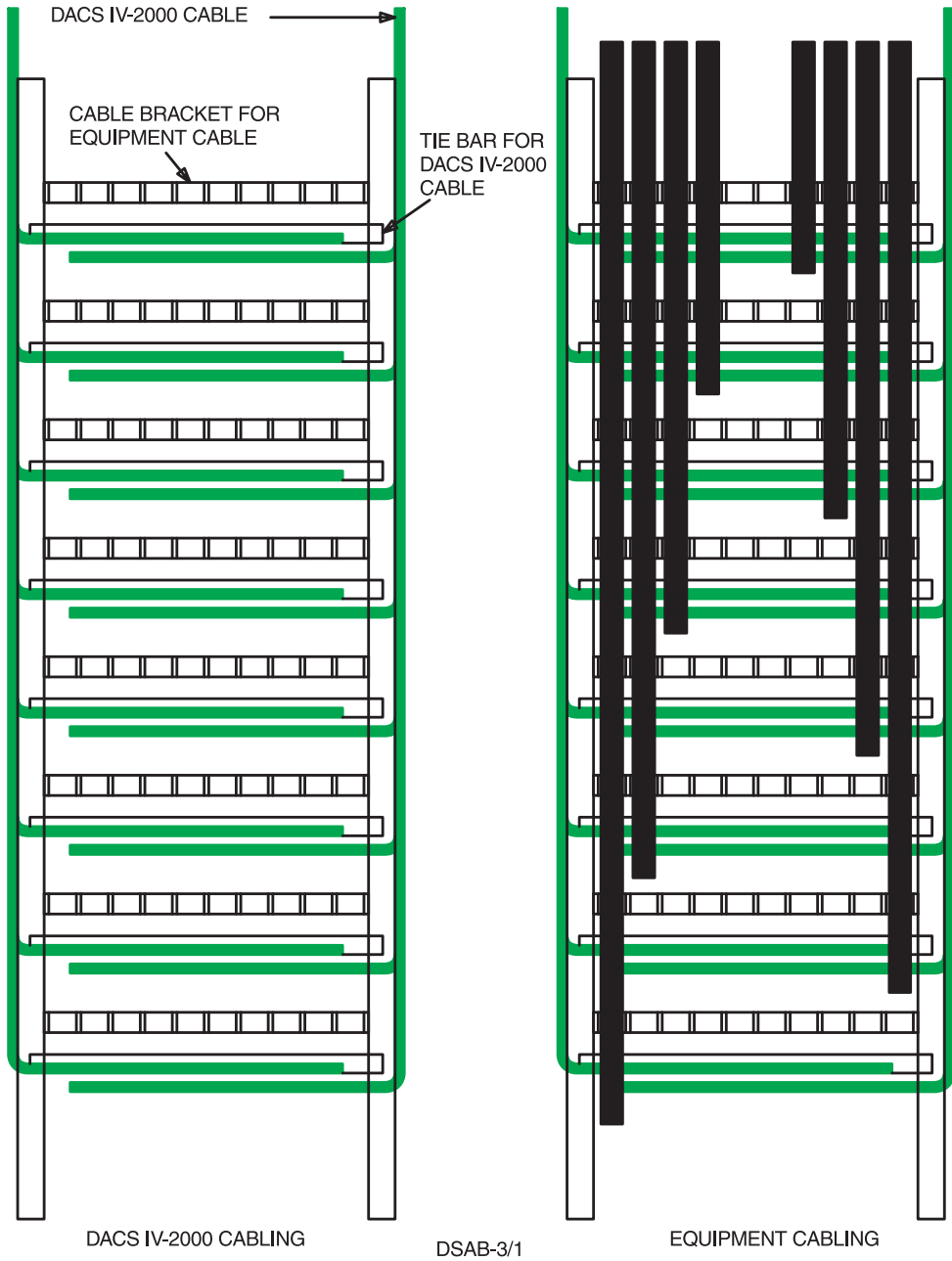

Figure 7. DSAB3/1 DACS and Equipment Cabling

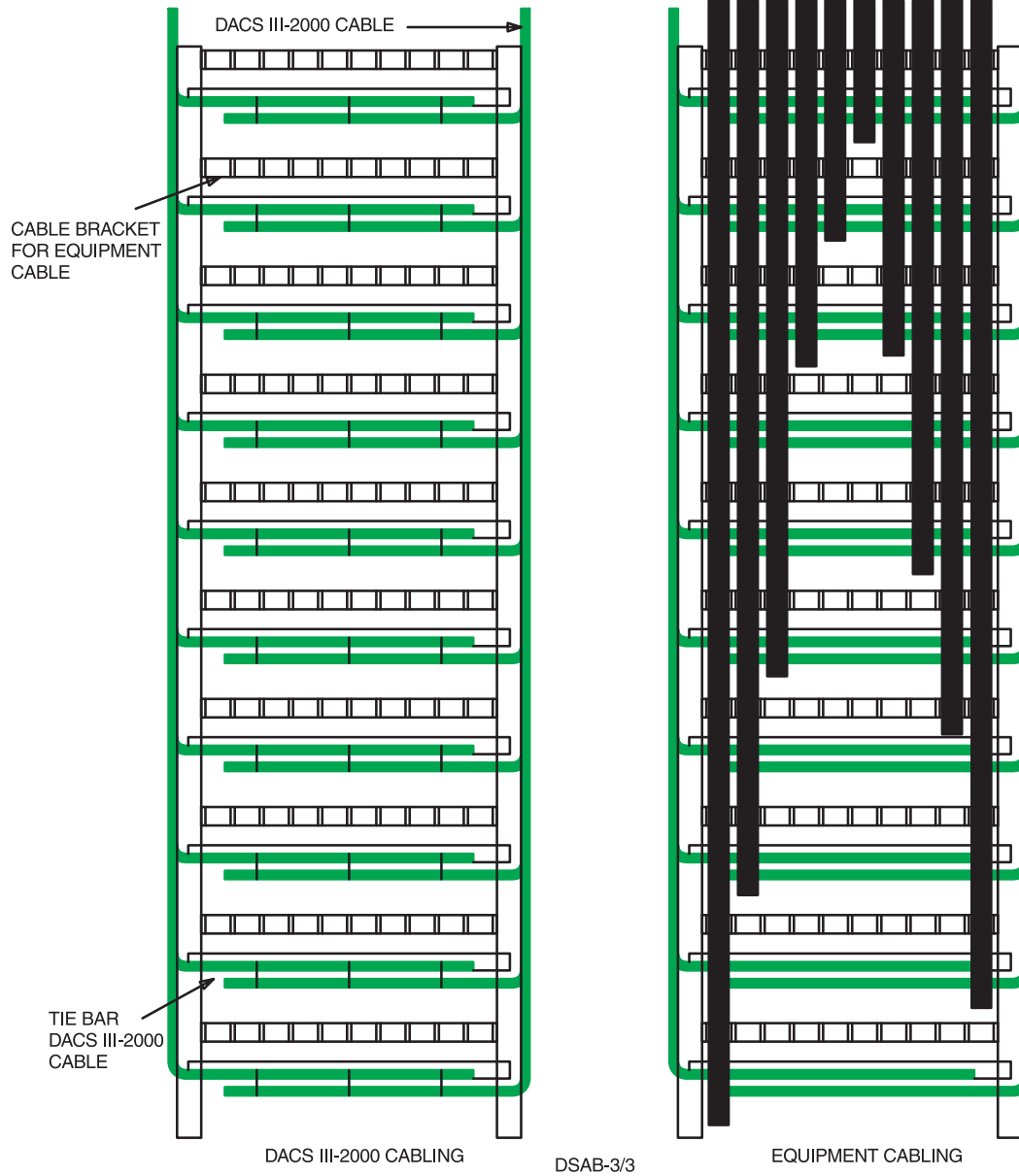

Figure 8. DSAB3/3 DACS and Equipment Cabling