

General

This instruction sheet provides the procedure to be followed when installing adhesive-backed vertical label holders on double-loop vertical troughs. These vertical label holders and vertical troughs are designed to be used with the 900-NSD-Series DSX-1/1C framework hardware. For vertical trough information, see instruction sheet 365-301-120-23.

How to Contact Us

- To find out more about **Carrier Apparatus** products, visit us on the web at: <http://cw.commscope.com/>
- For technical assistance regarding Carrier Apparatus products: contact your local CommScope account representative or CommScope technical support at 1-800-344-0223.
- Report any missing or damaged parts to CommScope customer service in Omaha, Nebraska, at 1-866-539-2795.

References

- *365-301-120, 800-Series and 900-Series DSX-1/1C Systems, System Reference Guide.*

VERTICAL LABEL HOLDER INSTALLATION

Refer to Figure 1.

⇒ NOTE:

Figure 1 shows a full vertical trough with the label holders being installed on both sides. Half vertical troughs (refers to troughs that are half the width of full vertical troughs) use only one label holder, which is installed on one side.

1. Wipe the indicated area on the vertical trough with alcohol wipes (included in package).
2. Peel the protective covering from double-sided adhesive tape (attached to label holder) and affix the label holder to either side of the vertical trough.

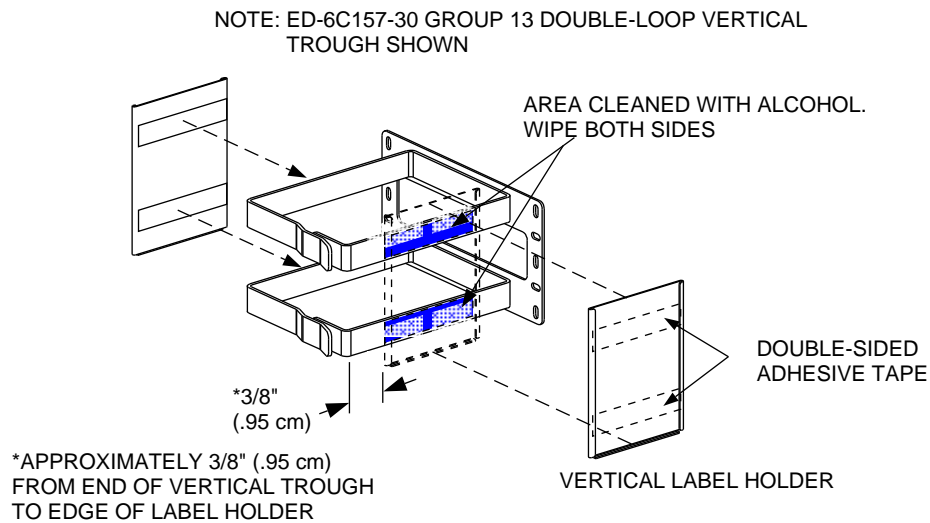

Figure 1. Vertical Label Holder Installation