

⚠ CAUTION:

Spray cleaners can damage plastic parts. Do not apply any sprays or cleaners to this product that have not been approved. Be especially careful not to expose any plastic parts to chemicals containing trichlorethane, such as certain cleaning fluids and lubricant sprays.

General

This instruction sheet provides the procedures for installing and cabling wall mount combined Digital Interconnect and Cross-Connect Interface (DIXI-1) and Digital Distribution Interface (DDI) System panels and panel assemblies.

Equipment Description

The DIXI-1 wall mount panel can accommodate four DIXI-1 modules with four DIXI-GR1A ground plates (16 circuits total). There is also space on the panel for two DDI modules (four circuits each). An empty version of the panel is also available for customized capacity with separately orderable DIXI-1 and DDI blocks.

Table 1 lists each panel type and associated ordering information.

Table 1: DIXI-1 Wall Mounted Ordering Information

Application	Apparatus Code	Material ID	Description
DIXI-1 (All)	DIXI1/4A1-4	106 972 292	Standard 4-circuit DIXI-1 connecting block
	DIXI/4A1-0	107 396 137	Blank faceplate to fill empty panel slots
	DIXI-GR1A	107 503 690	Ground plate 0.040 in. (1.0 mm) thick for ground connections
DIXI-1 Interconnect Cross-Connect (Wall Mount)	DIXI-P13/5B1-16	107 540 437	16-circuit wall mount panel assembly 5" H x 14" W x 6" D (127 x 356 x 152 mm), four DIXI blocks, four DIXI-GR1A ground plates, and one horizontal circuit identification label
	DIXI-P13/5B1-0	107 493 157	Empty wall mount panel 5" H x 14" W x 6" D (127 x 356 x 152 mm), one horizontal circuit identification label, no blocks.
DDI	DDI-BAL 8A1-BNC	106 655 368	DDI balun block, 8 BNC terminations (4-circuit)
	DDI-BAL8B1-BNC	108 552 134	DDI balun block, 8 BNC terminations (4-circuit) See Note below.
Note: This DDI block meets ITU minimum provisional return loss for CEPT-1/E1 within the temperature range of -40° C. to +55° C.			

Parts List

Refer to the stock list packaged with this instruction sheet for a complete list of parts.

How to Contact Us

- To find out more about **Carrier Apparatus** products, visit us on the web at: <http://cw.commscope.com/>
- For technical assistance regarding Carrier Apparatus products: contact your local CommScope account representative or CommScope technical support at 1-800-344-0223.
- Report any missing or damaged parts to CommScope customer service in Omaha, Nebraska, at 1-866-539-2795.

Tools Required

<ul style="list-style-type: none">• Cable Stripper	<ul style="list-style-type: none">• Wire-wrap gun — with minimum 5-inch (127 mm) extension bit
<ul style="list-style-type: none">• Screw-starter	<ul style="list-style-type: none">• Flat-blade 0.2-inch (5 mm) wide screwdriver, 6 inches (152 mm) long
<ul style="list-style-type: none">• Wire Stripper	<ul style="list-style-type: none">• Cable ties and/or lacing cord
<ul style="list-style-type: none">• Spudger	

References

- 365-301-121 — *DIXI-1 System Reference Guide*
- 365-301-121-1 — *DIXI-1 Connecting Block, Installation and Removal*
- 365-301-121-2 — *DIXI-1 Panel Assemblies, Installation and Cabling*
- 365-301-121-3 — *DIXI-1 Panel Assemblies With Ground Plate, Installation and Cabling*
- 365-301-121-4 — *DIXI-GR1A Ground Plate Installation Instructions*
- CIR #201-099-024 TD Blue and Orange Test Cords

DIXI-1 PANEL INSTALLATION AND CABLING

STEP 1—INSTALL WALL MOUNT PANEL ASSEMBLY

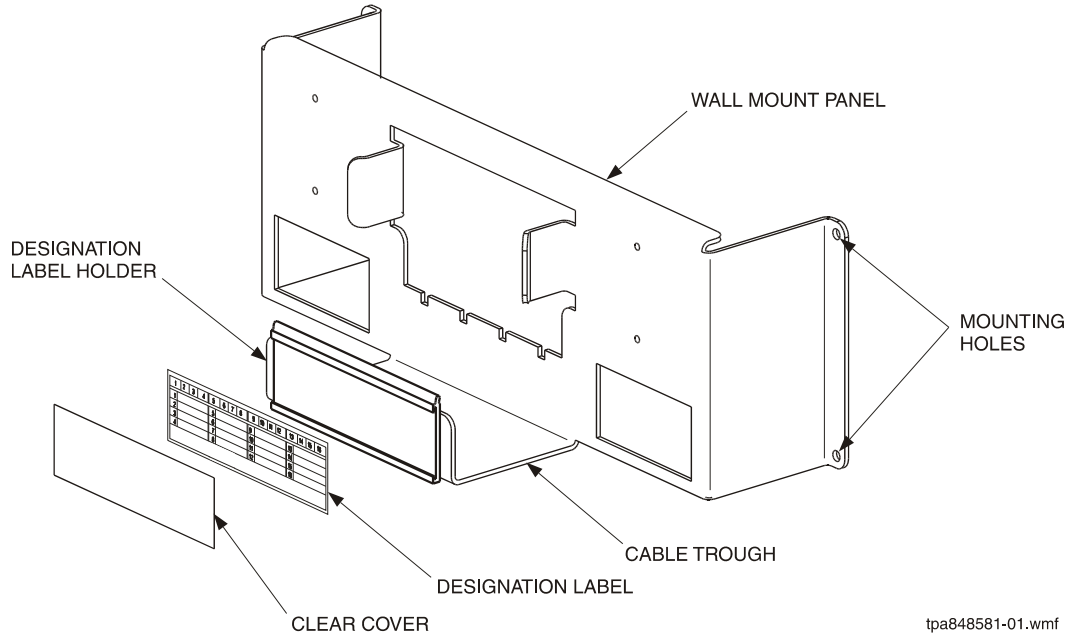

1. Locate panel mounting position on wall and secure with appropriate hardware in the four corner holes.
2. Slide equipment designation label and clear plastic cover into designation strip holder on cable trough.

STEP 2—ROUTE DCS CABLING TO PANEL

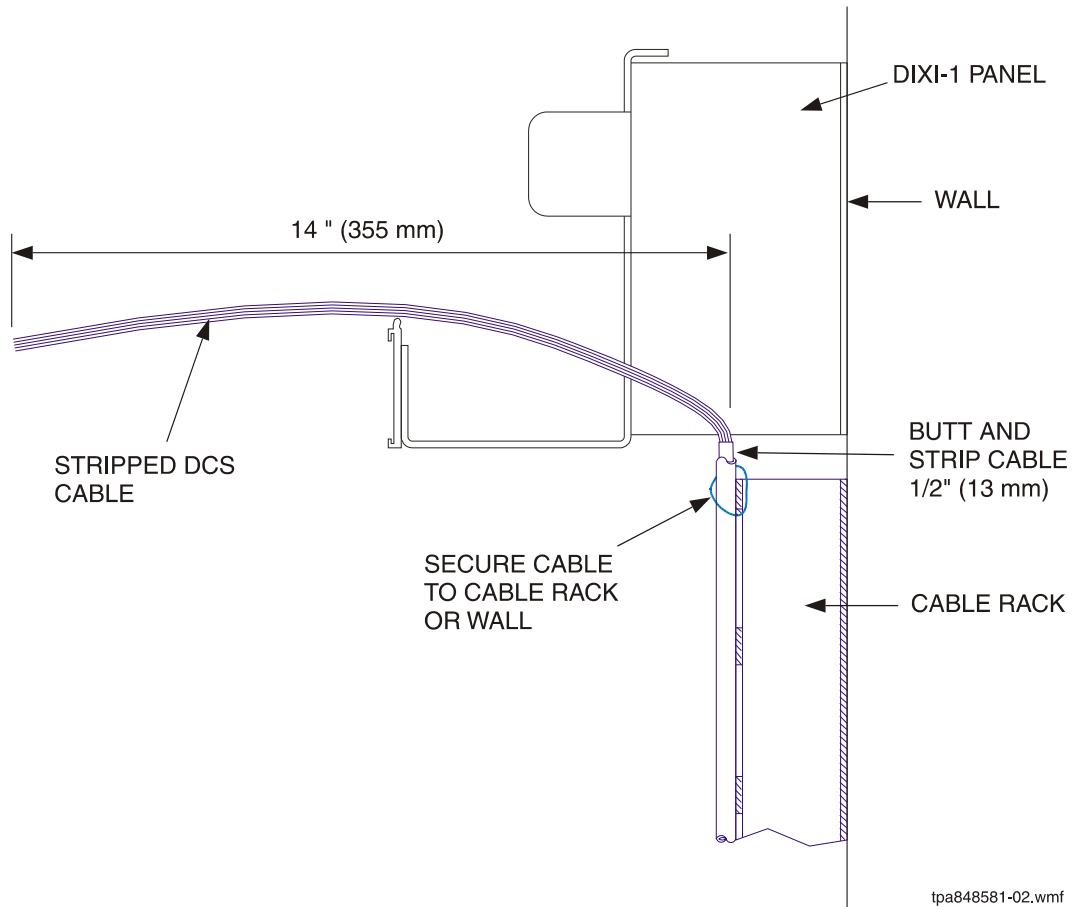

1. Secure DCS cables to wall and/or cable rack behind panel.
2. Butt and strip cables 1/2 inch (13 mm) beyond where they are secured allowing a minimum 14 inches (355 mm) conductor length.
3. Partition conductors to each block and secure with twine or nylon ties.

STEP 3—CONNECT DCS CABLING

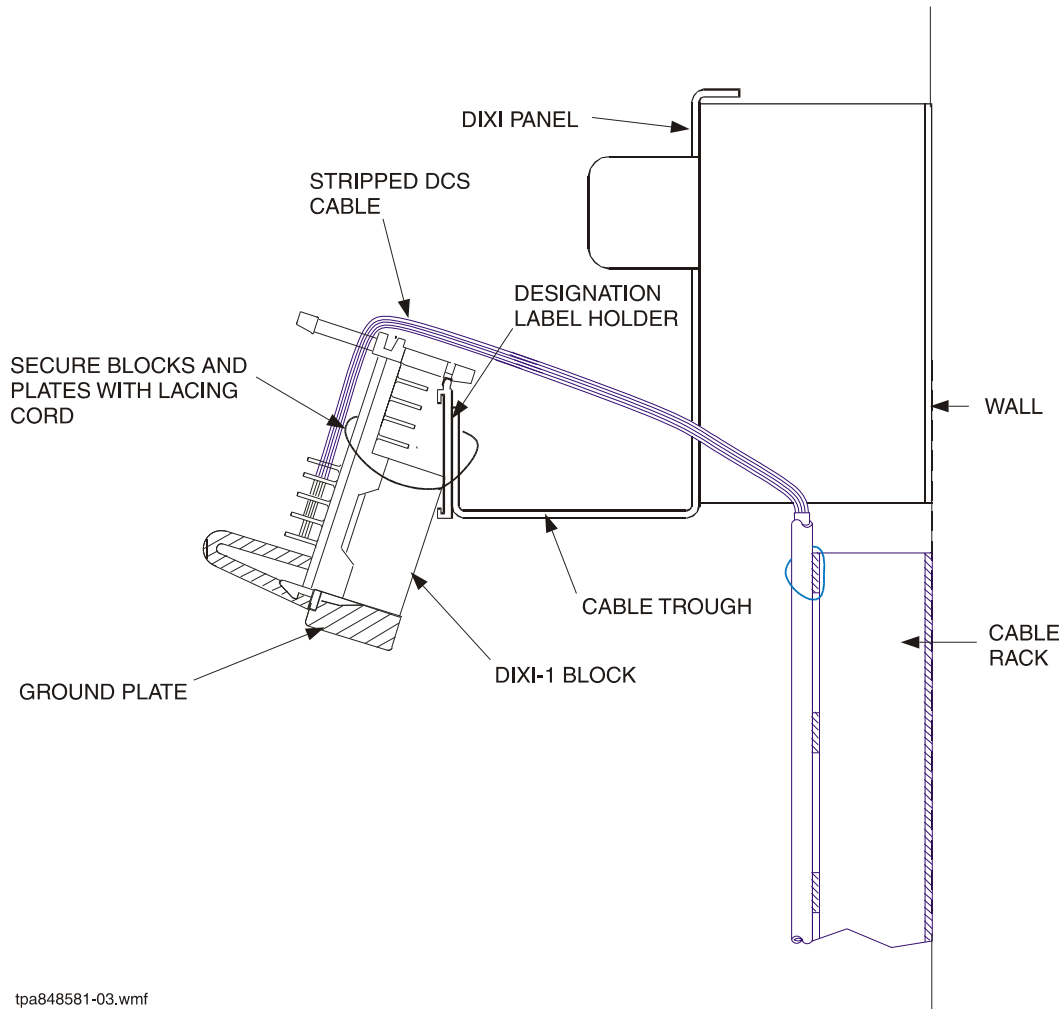

tpa848581-03.wmf

1. Hang ground plates and blocks (starting with a plate, work left to right, one plate per block) on designation strip of panel, with rear of block facing out. When hung in this position, the circuit termination identification on rear of block is "left-to-right" to aid wiring operations.
2. Secure blocks and plates to panel cable trough using lacing cord.
3. Pull free-end of formed cable legs and dress conductors over fanning strip and down across rear of block. Each block requires its own conductor group.
4. Strip conductors and wire-wrap them to corresponding terminals. Transmit circuits terminate on OUT pins and receive circuits terminate on IN pins. Wrap ground (drain) wire for each pair to a pin on adjacent ground plate. If both transmit and receive circuits are connected, then each pin of ground plate will hold two ground wires. The fifth pin on ground plate is to allow all ground plates to be daisy-chained together in a common ground circuit. When daisy-chaining ground plates, leave a minimum 10-inch (254 mm) loop of wire between adjacent plates to allow removal of an individual plate from a completed assembly.
5. Dress terminated conductors by snapping them through slotted fanning strip.

STEP 4—FORM DCS CABLE AND INSTALL BLOCKS AND GROUND PLATES

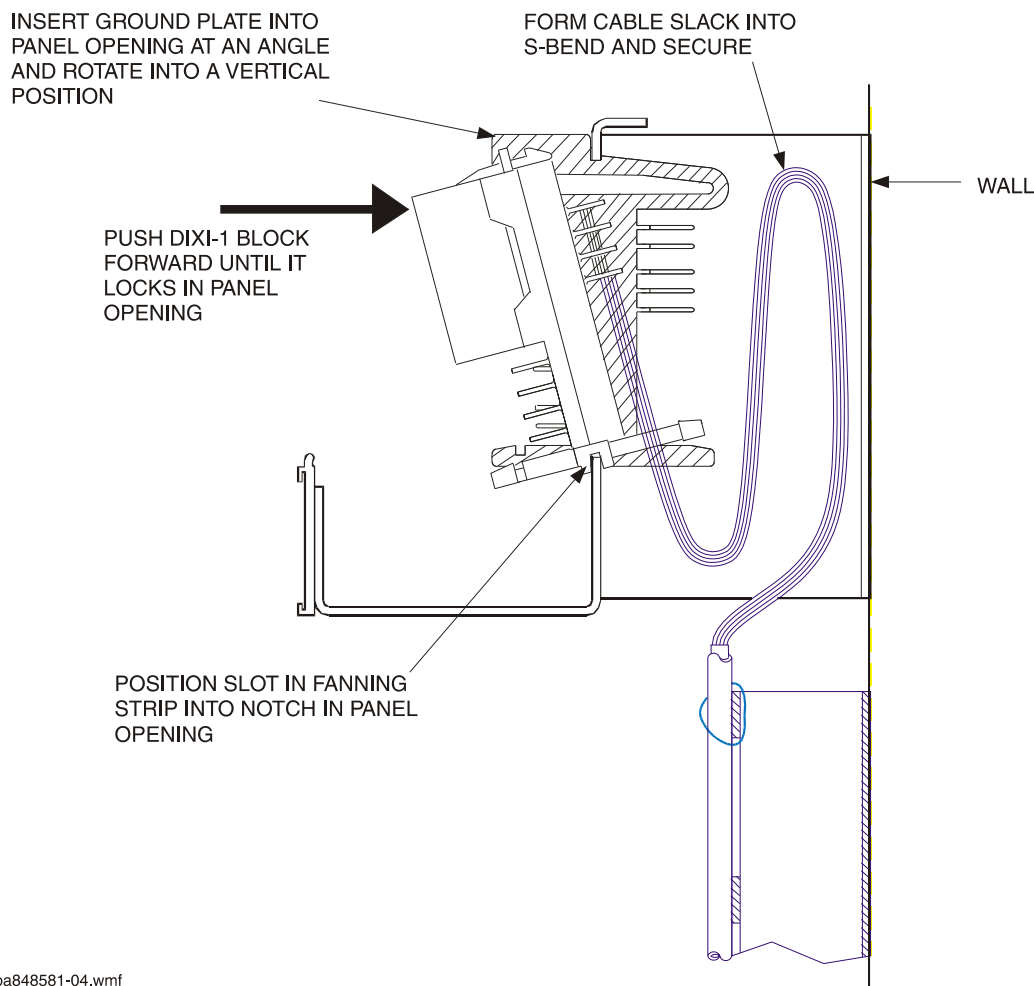

tpa848581-04.wmf

1. Cut lacing cord securing blocks.
2. Form cable slack into a “S-bend” and secure with twine or nylon ties. Leaving slack simplifies future block replacement and DCS circuit redistribution procedures.
3. Lift and rotate each ground plate and DIXI block, placing notch on bottom of each ground plate and slot on bottom of each fanning strip onto sawtooth edge of panel. *All ground plates must be constrained either between two DIXI blocks or between a DIXI block and one of the tabs at each end of panel. Installation should start from left side and work to the right.*
4. Ground plates must be cocked slightly to the side and rotated into a vertical position with the spring loaded notch capturing top edge of panel opening.
5. Push DIXI block into opening until latch on block locks into panel.
6. Verify all blocks are properly installed by grasping each block at top and pulling from the front with a moderate force, approximately 10 pounds (4.5 kg). Blocks should not pull out.

STEP 5—ROUTE AND CONNECT NETWORK ELEMENT CABLING TO DIXI-1 PANELS AND GROUND PLATES

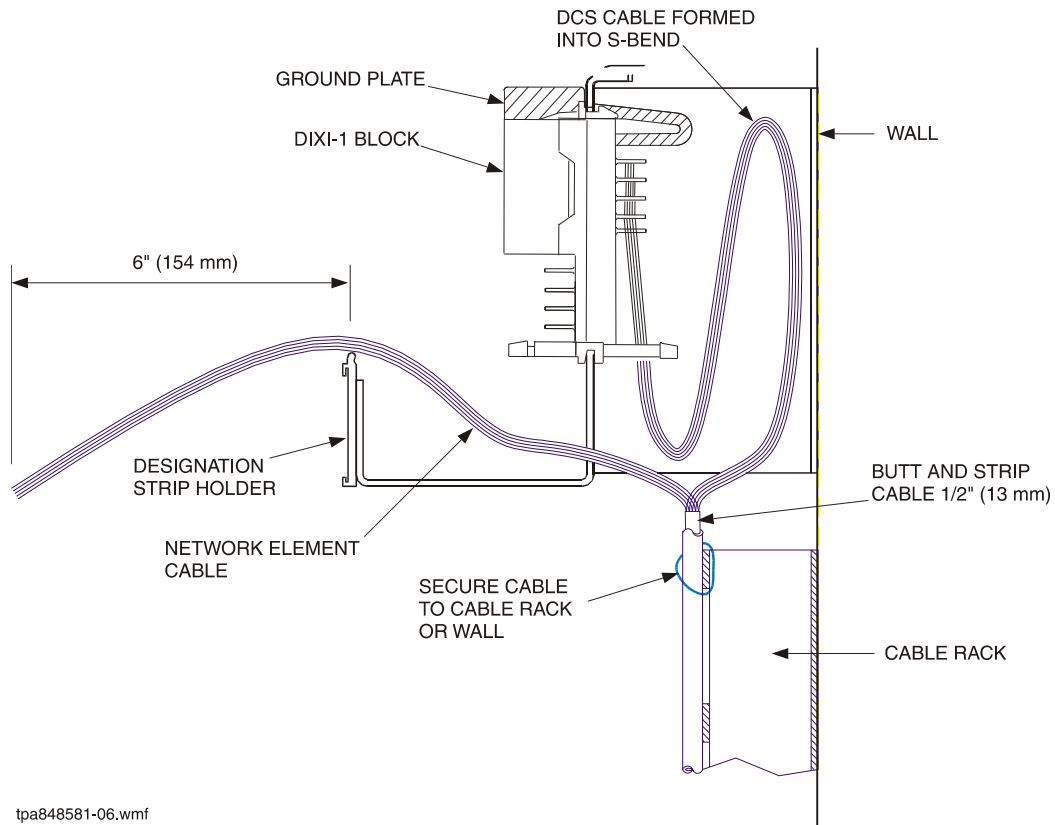

1. Secure network element cabling to wall and/or cable rack near panel center.
2. Butt and strip cables 1/2-inch (13 mm) beyond where they are secured allowing a minimum of 6 inches (152 mm) of conductor length beyond designation strip holder.
3. Partition conductors to each block and ground plate, then secure with twine or cable ties.

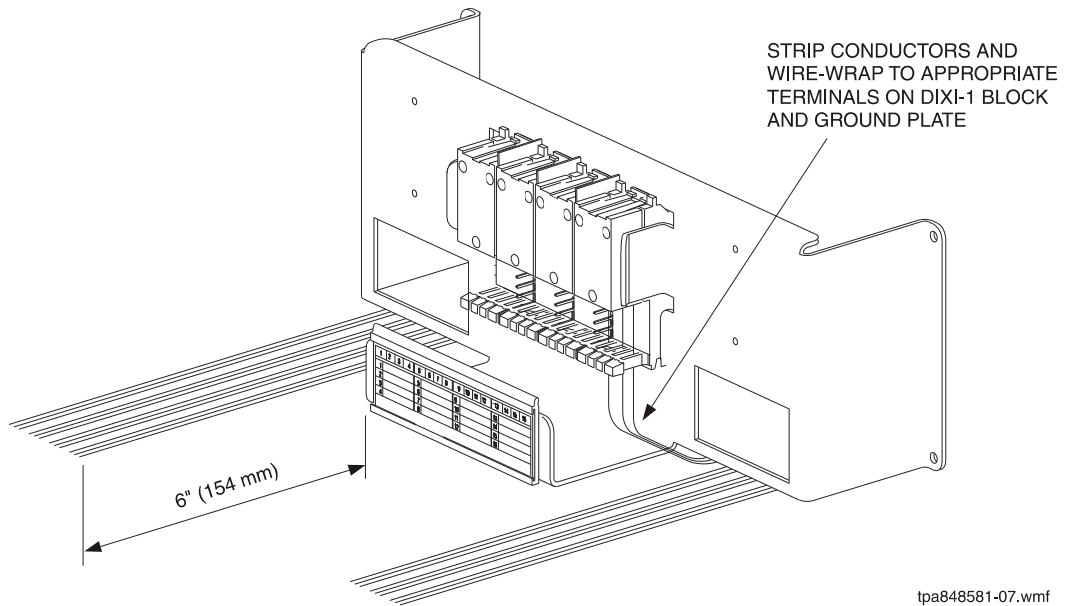

4. Strip conductors and wire-wrap them to corresponding terminals. Ground (drain) wire for each shielded pair is wrapped to a terminal on adjacent ground plate. Transmit circuits terminate on IN pins (bottom two rows) and receive circuits terminate on OUT pins (top two rows).
5. Dress terminated conductors by snapping them through slotted fanning strip.

DDI INSTALLATION AND CABLING

STEP 6—INSTALL LABELS IN DDI CONNECTING BLOCK

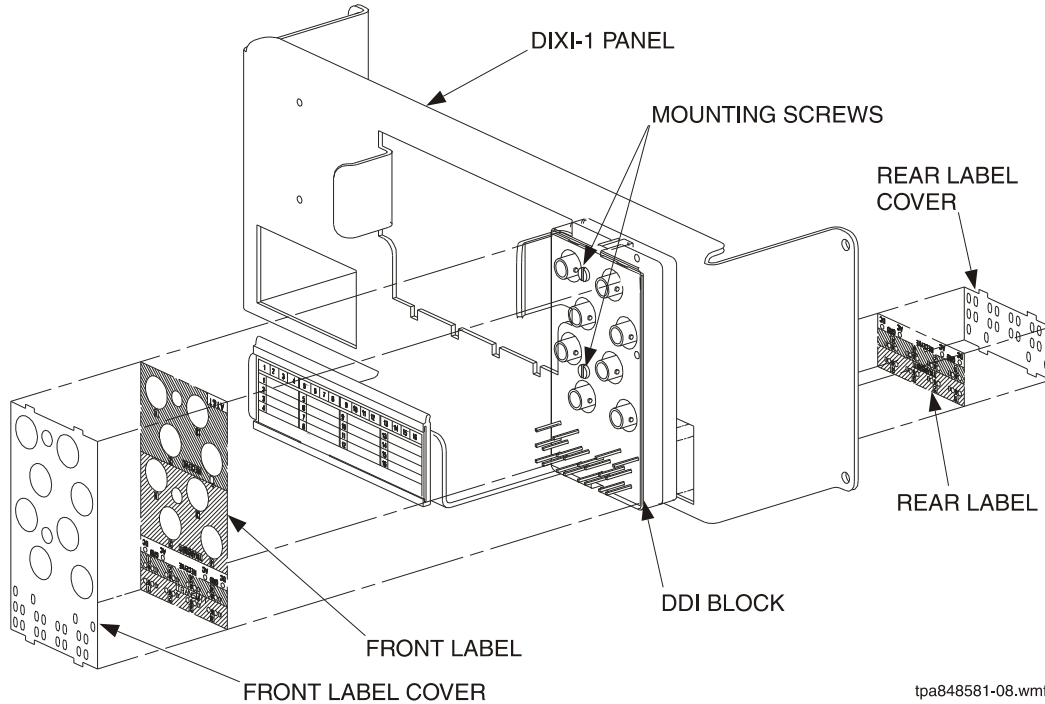

➤ NOTE:

Shading on DDI connecting block labels denotes which set of terminations (BNCs and wirewrap pins) are associated together. For example, each circuit that consists of a TRANSMIT BNC and TRANSMIT wirewrap pins are connected through a transformer. The TRANSMIT GRD (grounding) pins are connected in series to all transmit circuits. One set of ground pins are associated with TRANSMIT terminations and other set of ground pins are associated with RECEIVE terminations.

➤ NOTE:

Install label and label cover onto each DDI block just prior to installing block on panel.

1. Select label set with the description in lower right-hand corner that reads: INVERTED; LEFT TO RIGHT NUMBERING 846 926 095.
2. Tear each label along perforation.
3. Install labels first on block for left side of panel. Place front and rear labels into recessed area of DDI connecting block, over the BNC connectors and wirewrap pins.
4. Peel off protective covering from front and back of each label cover.
5. Install DDI block onto left side of panel.
6. Repeat instructions 3 through 6 for DDI block on right side of panel.