

**ED-6C157-30 FRAMEWORK HARDWARE
DSX-1/1C, DIXI, and DSX-3R SYSTEMS
INSTALLATION PROCEDURES FOR
LABEL SETS AND OPERATIONS DECAL**

General

This instruction sheet provides procedures for installing the label sets and decals available from ED-6C157-30. These label sets and decals are used with the DSX-1/1C Systems (**Bantam Plus**[™] and 800- and 900-Series), and the Digital Interconnect and Cross-Connect Interface Systems (DSX-3R, DIXI-1 and DIXI-3).

How to Contact Us

- To find out more about **Carrier Apparatus** products, visit us on the web at: <http://cw.commscope.com/>
- For technical assistance regarding Carrier Apparatus products: contact your local CommScope account representative or CommScope technical support at 1-800-344-0223.
- Report any missing or damaged parts to CommScope customer service in Omaha, Nebraska, at 1-866-539-2795.

References

- 365-301-120, *800-Series and 900-Series DSX-1/1C, System Reference Guide*
- 365-301-125, *Bantam Plus 2DSX-1/1C, System Reference Guide*
- 365-301-121, *DIXI-1 System, System Reference Guide*
- 365-301-131, *DIXI-3 System, System Reference Guide*
- ED-6C152-12—*900-NSD System, Engineering and Ordering*
- ED-6C157-10—*DSX-1/1C and DIXI System, Framework Engineering, Hardware and Ordering*
- ED-6C157-31—*DSX-1/1C, DIXI, and DSX-3R Systems, Framework Hardware Groups*
- ED-6C156-10—*Bantam Plus DSX-1/1C System, Engineering and Ordering*
- ED-6C155-10—*DIXI-1 System, Engineering and Ordering*
- ED-6C155-11—*DIXI-3 System, Engineering and Ordering*
- ED-6C155-14—*DSX-3R System, Engineering and Ordering.*

Tools Required

- Screw-starter
- Flat blade 0.2-inch (5 mm) wide, 6-inch (152 mm) long screwdriver.

Ordering Information

Apparatus Code	Material ID	See Page	Description
ED-6C157-30, Group 43	601 423 601	3	Label set—1-56, 1-64, 1-80, 1-84, 1-90 and A, B, and C.
ED-6C157-30, Group 62	601 452 832	4	Two label assembly sets for DIXI-3 panels. Includes labels, holders, and protective covers.
ED-6C157-30, Group 72	601 458 193	5	Designation strip and cover for 800-Series DSX panels.
ED-6C157-30, Group 73	601 458 201	5	Label set for 800-Series DSX panels.
ED-6C157-30, Group 78	601 461 056	6	Operations decal—800-Series and 900-Series DSX.
ED-6C157-30, Group 81	601 784 283	5	One designation strip for 900 DSX panel. Includes cover and instructions.
ED-6C157-30, Group 85	601 798 150	7	Two label holders and one label set for up to 84 circuits of Bantam Plus modular staggered-jack, rear/rear DSX1/1C panels. For 5-inch (127 mm) bay spacings.
ED-6C157-30, Group 87	601 838 394	7	Two label holders and two sets of circuit designation labels for Bantam Plus modular staggered-jack, rear/rear DSX1/1C panels in all line-up spacing configurations including zero-inch bay spacing.
ED-6C157-30, Group 92	601 868 540	8	Two multifold style label holders and two sets of circuit designation labels for Bantam Plus modular staggered-jack, rear/rear DSX1/1C panels in all line-up spacing configurations including zero-inch bay spacing.
ED-6C157-30, Group 104	601 978 885	3	One vertical trough label set for System III DSX-3R circuit panel.
ED-6C157-30, Group 108	601 978 843	4	One panel label set for the System III DSX-3R 24-circuit panel.

INSTALLING GROUP 43 AND GROUP 104: LABEL ASSEMBLY SET FOR *BANTAM PLUS* DSX-1 and DSX3R HARDWIRED PANELS

1. Slide the appropriate label into the designation label holder.
2. Slide the clear protective cover over the label.

2.80" (71 mm)

	1					2	3	4	5	6								
2.44" (62 mm)	1	15	29	43	57	71	1	12	23	33	44	55	1	15	29	41	55	69
	2	16	30	44	58	72	2	13	24	34	45	56	2	16	30	42	56	70
	3	17	31	45	59	73	3	14	25	35	46	57	3	17	31	43	57	71
	4	18	32	46	60	74	4	15	26	36	47	58	4	18	32	44	58	72
	5	19	33	47	61	75	5	16	27	37	48	59	5	19	33	45	59	73
	6	20	34	48	62	76	6	17	28	38	49	60	6	20	34	46	60	74
	7	21	35	49	63	77	7	18	29	39	50	61	7	21	35	47	61	75
	8	22	36	50	64	78	8	19	30	40	51	62	8	22	36	48	62	76
	9	23	37	51	65	79	9	20	31	41	52	63	9	23	37	49	63	77
	10	24	38	52	66	80	10	21	32	42	53	64	10	24	38	50	64	78
	11	25	39	53	67	81	11	22	33	43	54	65	11	25	39	51	65	79
	12	26	40	54	68	82	12	23	34	44	55	66	12	26	40	52	66	80
	13	27	41	55	69	83							13	27	41	53	67	81
	14	28	42	56	70	84							14	28	42	54	68	82

FRONT

1	11	21	29	39	49	1	15	31	36	51	75	1	15	31	36	51	75
2	12	22	30	40	50	2	16	32	37	52	76	2	16	32	37	52	76
3	13	23	31	41	51	3	17	33	38	53	77	3	17	33	38	53	77
4	14	24	32	42	52	4	18	34	39	54	78	4	18	34	39	54	78
5	15	25	33	43	53	5	19	35	40	55	79	5	19	35	40	55	79
6	16	26	34	44	54	6	20	36	41	56	80	6	20	36	41	56	80
7	17	27	35	45	55	7	21	37	42	57	81	7	21	37	42	57	81
8	18	28	36	46	56	8	22	38	43	58	82	8	22	38	43	58	82
9	19	29	37	47	57	9	23	39	44	59	83	9	23	39	44	59	83
10	20	30	38	48	58	10	24	40	45	60	84	10	24	40	45	60	84

BACK

SELECT APPROPRIATE LABEL FROM THE SIX PROVIDED AND DETACH

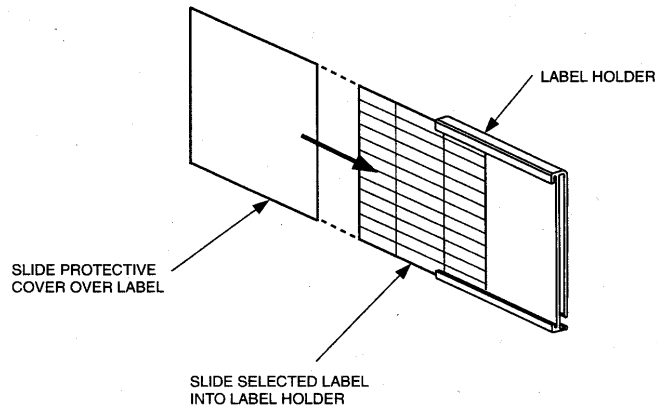

Figure 1. Installing Group 43 Label Assembly Set

INSTALLING GROUP 62: DIXI-3 LABEL ASSEMBLY SET

1. Move the panel mounting screws from the top and bottom holes to hole positions shown in.
2. Loosen *but do not remove* the panel mounting screws.
3. Slide label holders under panel and tighten the panel mounting screws.
4. Slide label and cover into label holder.

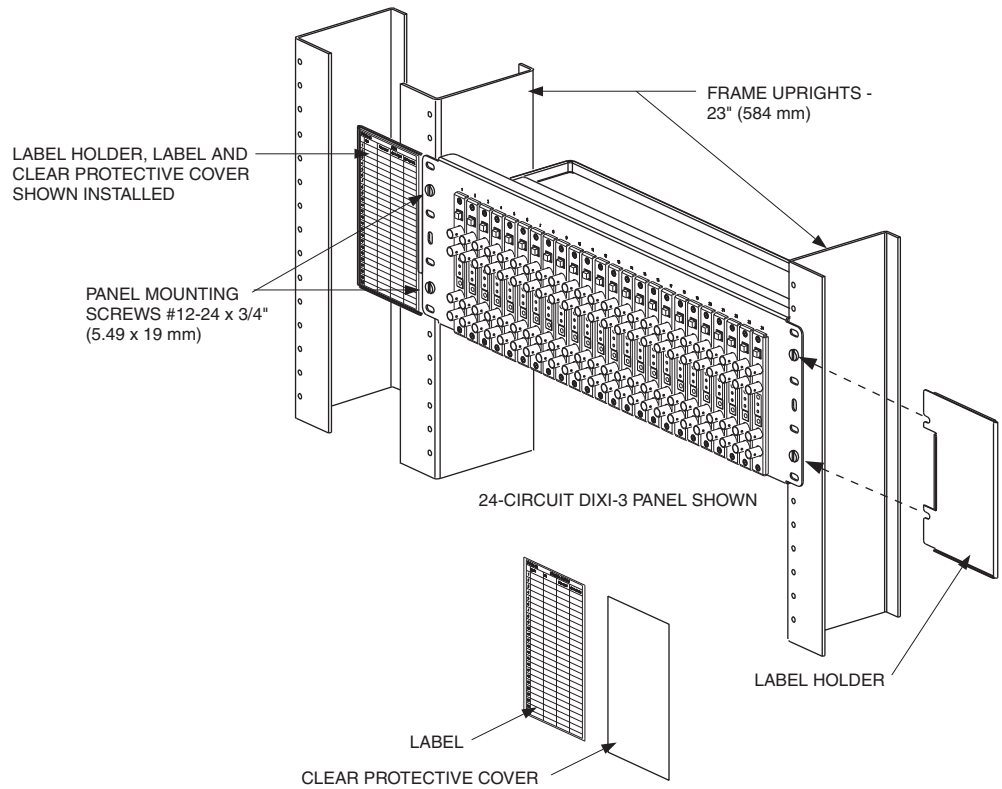

Figure 2. Installing Group 62 Label Assembly Set

INSTALLING GROUPS 72, 73, AND 81: 800/900-SERIES DSX PANEL DESIGNATION STRIP

1. Clean front of trough where panel designation strip will be secured.
2. Remove protective paper from adhesive backing on rear of panel designation strip.
3. Position strip so that bottom is even with bottom of trough and secure by pressing firmly on the front of it.
4. Slide label strip and clear protective cover into panel designation strip.

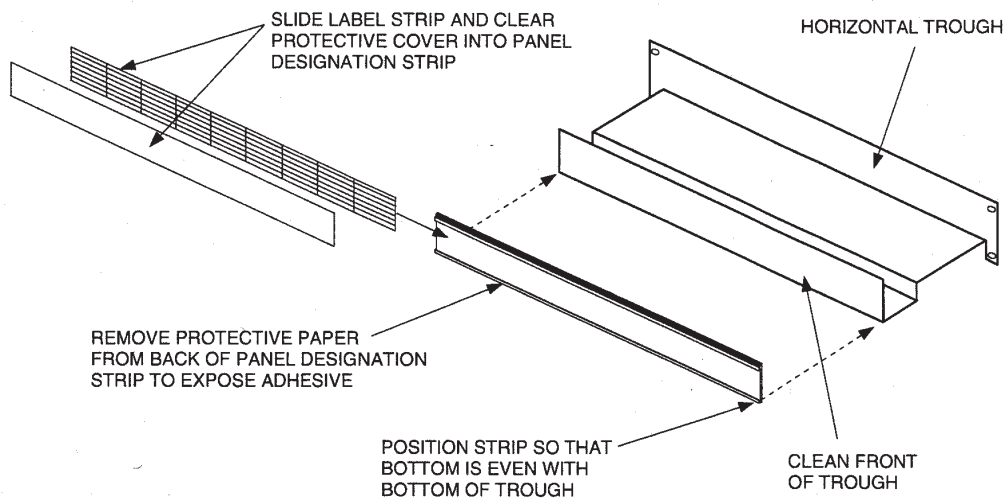

Figure 3. Installing Groups 72, 73, and 81 Designation Strip

INSTALLATING GROUP 78: 800/900-SERIES OPERATIONS DECAL

1. Clean location on endguard cover assembly where operations decal will be located.

⇒ NOTE:

Be sure the endguard cover assembly is dry before securing decal.

2. Remove adhesive backing from decal, position it as shown, and press firmly to secure it to endguard cover assembly.

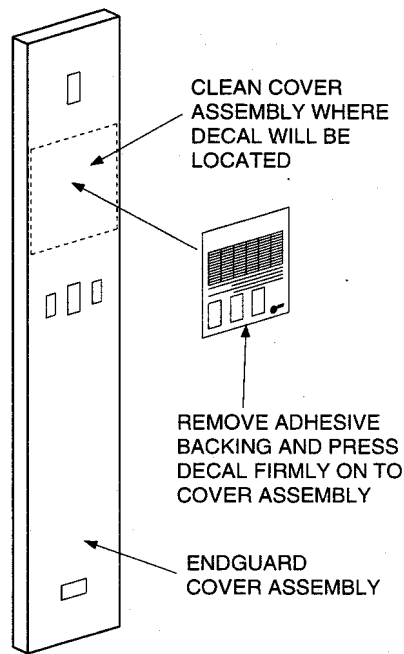

Figure 4. Installing Group 78 Operations Decal

INSTALLING GROUPS 85, 87, AND 105: LABEL HOLDERS FOR *BANTAM PLUS DSX-1*

1. Mount label holder under the panel mounting screw screwheads.
2. Tighten panel mounting screws to secure label holder.
3. Slide label set into label holder.

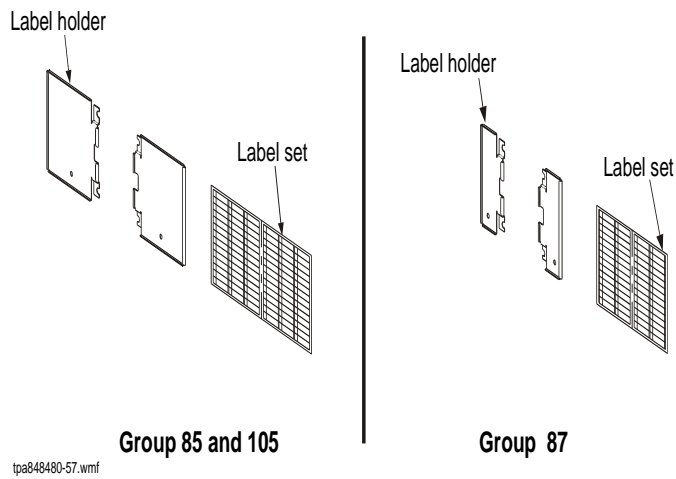

Figure 5. Installing Groups 85, 105, and 87 Label Holders

INSTALLING GROUP 92: LABEL HOLDER FOR *BANTAM PLUS* DSX-1

1. Loosen but do not remove the panel mounting screws.
2. Mount label holder bracket under the panel mounting flange.
3. Tighten panel mounting screws to secure panel and label holder bracket.
4. Press label clip into top hole in cable holder bracket.
5. Hang label set (cover, labels, and backing sheet) onto clip.

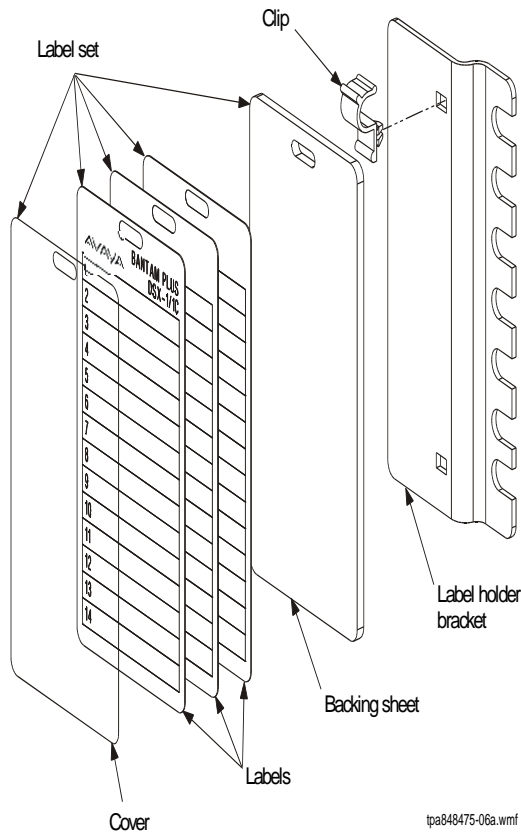

Figure 6. Installing Group 92 Label Holder