

Refer to Z-IDC Reference Manual, 201-205-001, for additional information.

## How to Contact Us

- To find out more about **Carrier Apparatus** products, visit us on the web at: <http://cw.commscope.com/>
- For technical assistance regarding Carrier Apparatus products: contact your local CommScope account representative or Commscope technical support at 1-800-344-0223.
- Report any missing or damaged parts to CommScope customer service in Omaha, Nebraska, at 1-866-539-2795.

## Application Notes

The Earth Ground Kit provides an earth path for **protectors** around the hinge point of a hinged mounting bracket (does not provide earth connection to the MDF ironwork). One Earth Ground Kit must be ordered separately and installed on any connecting block with a hinged bracket that will be equipped with Cartridge or Single-Pair Protectors.

## Tools Required:

- Screwdriver, Flat
- Wrench, 8 mm

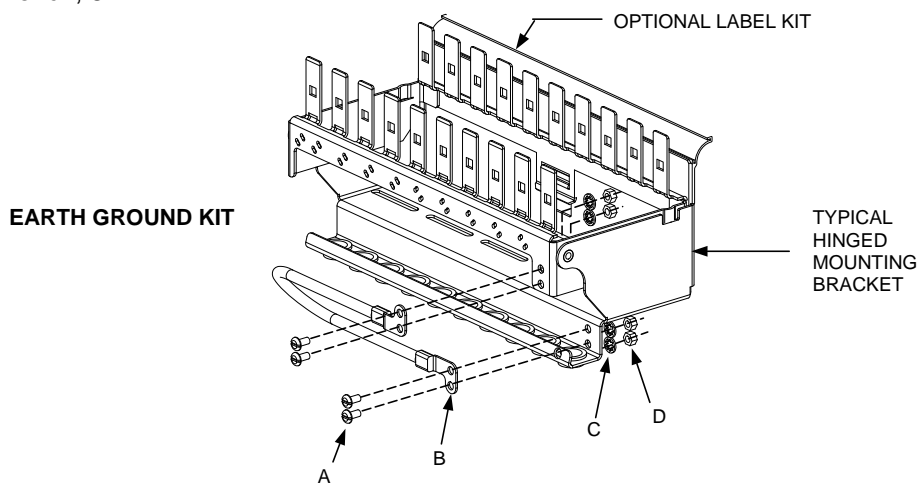

Items	Description
A	M5 x 0.8 x 8 mm Slotted Cheese Head Screw
B	Ground Strap Assembly
C	M5 Lock Washer
D	M5 Nut

1. Install Ground Strap Assembly (B) to hinged mounting bracket using screw (A), Washer (C) and Nut (D).

## Ordering Information

Description	Apparatus Code	Material ID
Earth Ground Kit (Optional)	ZIDC-G01	107 629 065