

DIXI-1 SYSTEM
DIXI-1 PANEL ASSEMBLIES WITH GROUND
PLATE INSTALLATION AND CABLING

⚠ CAUTION:

Spray cleaners can damage plastic parts. Do not apply any sprays or cleaners to this product that have not been approved. Be especially careful not to expose any plastic parts to chemicals containing trichlorethane, such as certain cleaning fluids and lubricant sprays.

General

The Digital Interconnect and Cross-Connect Interface (DIXI-1) System may be configured for either interconnect, cross-connect, or cabinet applications. This instruction sheet provides the procedures for installing and cabling DIXI-1 interconnect (64 circuit) and cross-connect (80 circuit) panel assemblies. For cabinet applications, consult your Lucent Technologies account representative for additional information. It is assumed that all necessary framework hardware and bay cabling has been installed.

Equipment Description

There are DIXI-1 panel assembly types available for each DIXI-1 application — interconnect, cross-connect, and cabinet. These particular DIXI-1 panel assemblies mount to the frame uprights of a standard 660 mm (26-inch) wide Network Bay Frame and can accommodate 20 DIXI-1 blocks (80 circuits total) or an ETSI Frame and can accommodate 16 DIXI-1 blocks (64 circuits total). Empty or “build-your-own” versions of each panel type are also available and allow the panel to be customized for a specific capacity with separately ordered DIXI-1 blocks. The panel types are:

- Interconnect Panel Assembly — consists of a 102 mm (4-inch) high panel and a 51 mm (2-inch) high transition trough. The transition trough allows cable leads to be brought to the rear of the bay for overhead cable management.
- Cross-Connect Panel Assembly — consists of a 127 mm (5-inch) high panel equipped with a horizontal jumper trough.

Application	Apparatus Code	Material ID	Description
All	DIXI/4A1-4	106 972 292	4-circuit DIXI-1 block assembly
	DIXI/4A1-0	107 396 137	Blank faceplate to fill empty panel slots.
	DIXI-GR1A	107 503 690	Ground plate [1 mm (0.040") thick] for ground connections.
Interconnect	DIXI-P21/6B1-64	107 486 292	64-circuit panel assembly 152 mm H (6") total, 102 mm H x 533 mm W (4" x 21") panel, 51 mm H x 533 mm W (2" x 21") transition trough, 16 blocks, 16 ground plates. Supplied with one horizontal circuit identification label.
	DIXI-P21/6B1-0	107 486 300	Empty panel assembly 152 mm H (6") total, 102 mm H x 533 mm H (4" x 21") panel, 51 mm H x 533 mm W (2" x 23") transition trough, no blocks or ground plates. Supplied with one horizontal circuit identification label.
	DIXI-TT21/2A1-0	107 486 318	Transition trough, 51 mm H x 533 mm W (2" x 21")
Cross-Connect	DIXI-PH23/5B1-0	107 542 557	Empty 80-circuit panel, 127 mm H x 584 mm W (5" x 23"), with horizontal jumper trough, no blocks or ground plates. Supplied with one horizontal circuit identification label.
	DIXI-PH23/5B1-80	107 504 078	80-circuit panel assembly, 127 mm H x 584 mm W (5" x 23"), with horizontal jumper trough, 20 blocks, 20 ground plates. Supplied with one horizontal circuit identification label.

How to Contact Us

- To find out more about **Carrier Apparatus** products, visit us on the web at:
<http://cw.commscope.com/>
- For technical assistance regarding Carrier Apparatus products: contact your local CommScope account representative or CommScope technical support at 1-800-344-0223.
- Report any missing or damaged parts to CommScope customer service in Omaha, Nebraska, at 1-866-539-2795.

Tools Required

- Cable Stripper
- Screw-starter
- Posidrive Screwdriver
- Spudger
- Wire Stripper
- Wire-wrap gun — with minimum 127 mm (5-inch) extension bit
- Flat blade 5 mm (0.2-inch) wide screwdriver, 152 mm long (6 inches)
- Cable ties and/or lacing cord
- 10 mm wrench

References

- 365-301-121 — *DIXI-1 System Reference Guide*
- 365-301-121-1 — *DIXI-1 Connecting Block, Installation and Removal*
- 365-301-121-2 — *DIXI-1 Panel Assemblies, Installation and Cabling*
- 365-301-121-4 — *DIXI-GR1A Ground Plate Installation Instructions*
- 365-301-121-5 — *Combined DIXI-1 and DDI Wall Mount Panel Assembly, Installation and Cabling*
- ED-6C155-10 — *DIXI-1 Engineering, Application and Ordering*
- ED-6C157-10 — *Digital Cross-Connect and Interconnect Framework Engineering, Hardware and Ordering*
- ED-6C157-30 — *DSX Framework Hardware Groups*
- ED-6C157-31 — *DSX Framework Hardware Groups*
- T6C100-12 — *Digital Transmission Facilities DIXI-1 Interconnection Circuit*

64-CIRCUIT INTERCONNECT PANEL INSTALLATION AND CABLING

STEP 1—DETERMINE PANEL MOUNTING POSITION

Figure 1 shows the recommended panel mounting positions, framework hardware positions, and cabling method for the 64-circuit DIXI-1 interconnect panels. This panel is also referred to as the “6-inch (152 mm) Panel.”

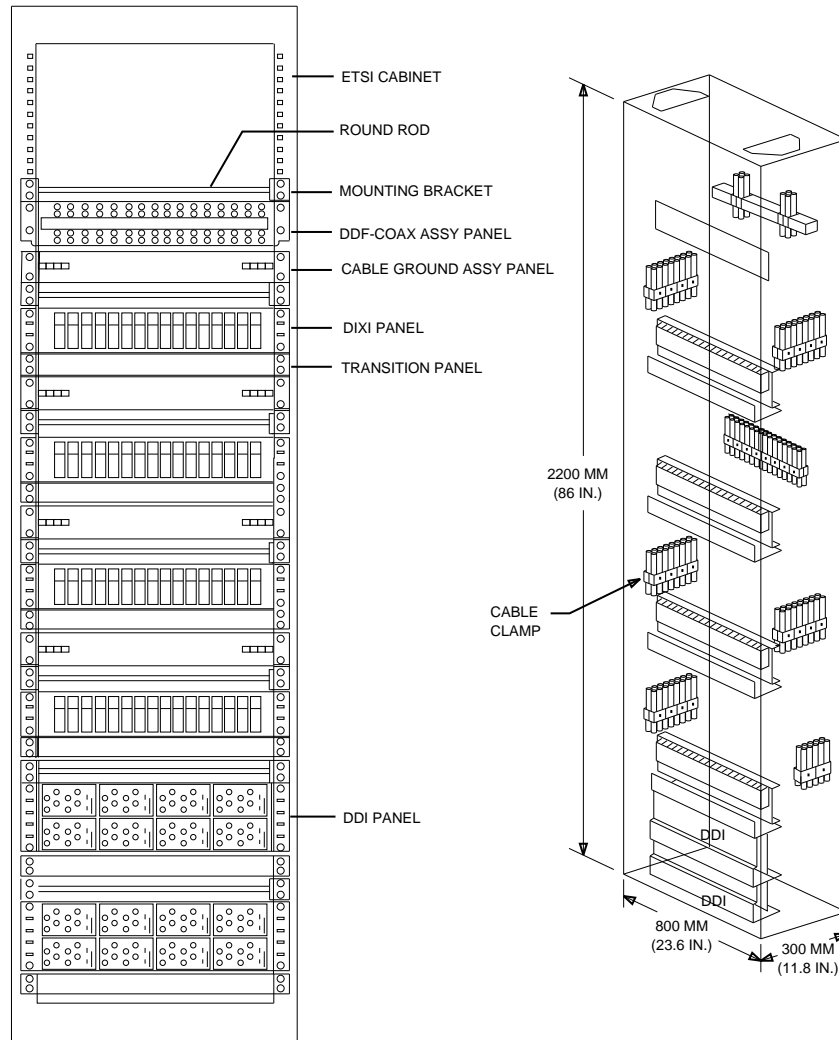

tpa 848424/01

Figure 1. 64 Circuit Interconnect Panel and Framework Hardware Mounting Positions

STEP 2—INSTALL INTERCONNECT PANEL ASSEMBLY

See Figure 2.

1. Locate panel mounting position on European Telecommunications Standards Institute (ETSI) cabinet and secure panel bracket with four M6 by 12 mm hex head screws provided with ETSI cabinet.
2. Secure transition panel directly below panel bracket and secure with four M6 by 12 mm hex head screws provided with ETSI cabinet.
3. Slide equipment designation label and clear cover into designation strip on transition panel.

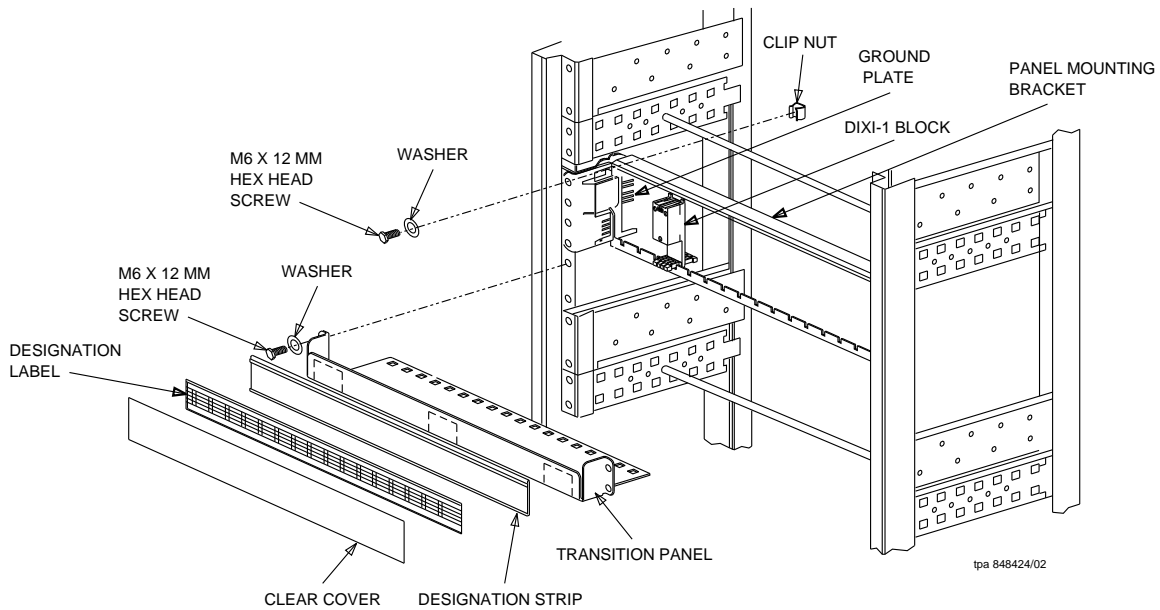
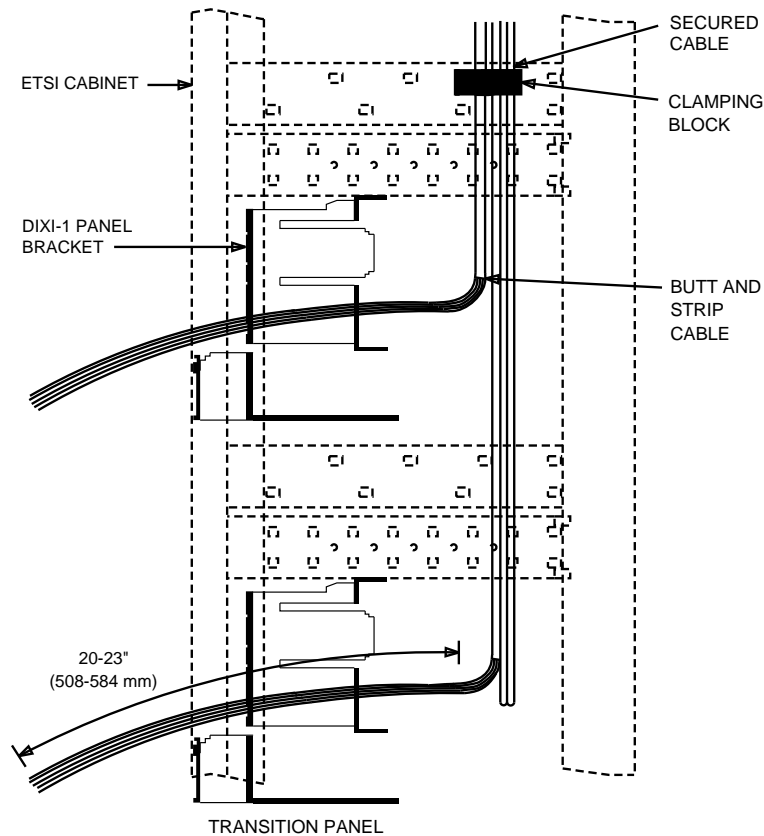

Figure 2. Install 64 Circuit DIXI-1 Interconnect Panel Assembly

STEP 3—ROUTE DCS CABLING TO DIXI-1 PANELS

Refer to Figure 3.

1. Route DCS cabling into proper clamping block in ETSI cabinet (see Figure 1).
2. Butt and strip cable, allowing conductor length a minimum of 914 mm (36 inches).
3. Partition conductors to each block position and secure to round rod with twine or nylon ties.
4. Cut remaining conductors to a length of 508-584 mm (20-23 inches) from secured position on round rod.



tpa 848424/03

Figure 3. Route DCS Cabling

STEP 4—CONNECT DCS CABLING

1. Hang ground plates and blocks (starting with a ground plate, working from left to right, one plate per block) on the designation strip of the panel bracket with rear of block facing out (see Figure 4). When hung in this position, the circuit termination identification on the rear of the block is “left-to-right” to aid wiring operations.
2. Secure blocks to the panel bracket with lacing cord.
3. Pull free end of formed cable legs and dress conductors over fanning strip and down across the rear of the block. Each block requires its own conductor group.
4. Strip conductors and wire-wrap them to corresponding terminals. Transmit circuits terminate on *OUT* pins and receive circuits terminate on *IN* pins. Wrap ground (drain) wire from each pair to a pin on the adjacent ground plate. If both transmit and receive circuits are connected, then each pin of the ground plate will hold two ground wires. The fifth pin on the ground plate is to allow all ground plates to be daisy-chained together in a common ground circuit. When daisy-chaining ground plates, leave a minimum 250 mm (10-inch) loop of wire between adjacent plates to allow the removal of an individual plate from a completed assembly.
5. Dress terminated conductors by snapping them through slotted fanning strip.

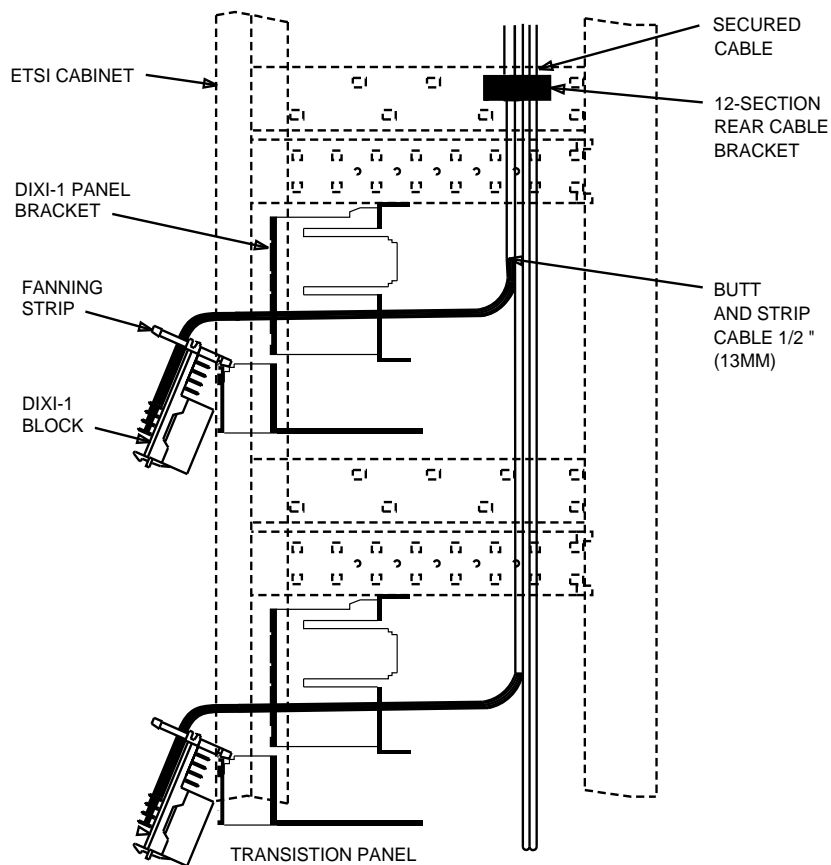

tpa 848424/04

Figure 4. Connecting DCS Cabling

STEP 5—FORM DCS CABLE AND INSTALL BLOCKS AND GROUND PLATES

Refer to Figure 5 and Figure 6 on page 9.

1. Cut lacing cord securing blocks.
2. Form cable slack (S bend) and secure with twine or nylon ties. Leaving slack simplifies future block replacement and DCS circuit redistribution procedures.
3. Install a ground plate at the left end of the panel by placing the notch at the bottom of the ground plate onto the sawtooth edge of the panel and rotate it into place. Ground plates must be cocked slightly to the side and rotated into a vertical position with the spring loaded notch capturing the top edge of the panel opening (see Figure 6). *All ground plates must be constrained*, either between two DIXI blocks, or between a DIXI block and one of the tabs at either end of the panel. Installation should start from the left side and work to the right.
4. Lift and rotate a DIXI block into place beside the ground plate. Place the slot at the bottom of each fanning strip onto sawtooth ledge of panel and rotate into place.
5. Push block into opening of panel bracket until latch on block *snap-locks* into panel bracket.
6. Repeat the above processes to install ground plates and DIXI blocks across the panel, sandwiching ground plates between DIXI blocks.
7. Verify all blocks are properly installed by grasping each block at top and pulling from the front with a moderate force of approximately 4.5 kg (10 pounds).

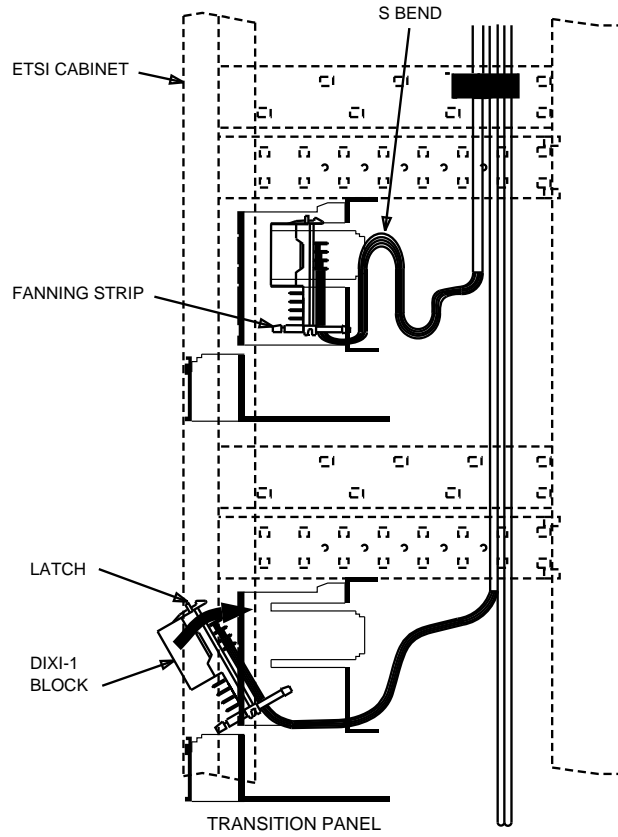

tpa 848424/05

Figure 5. Form Cable Slack and Install Blocks

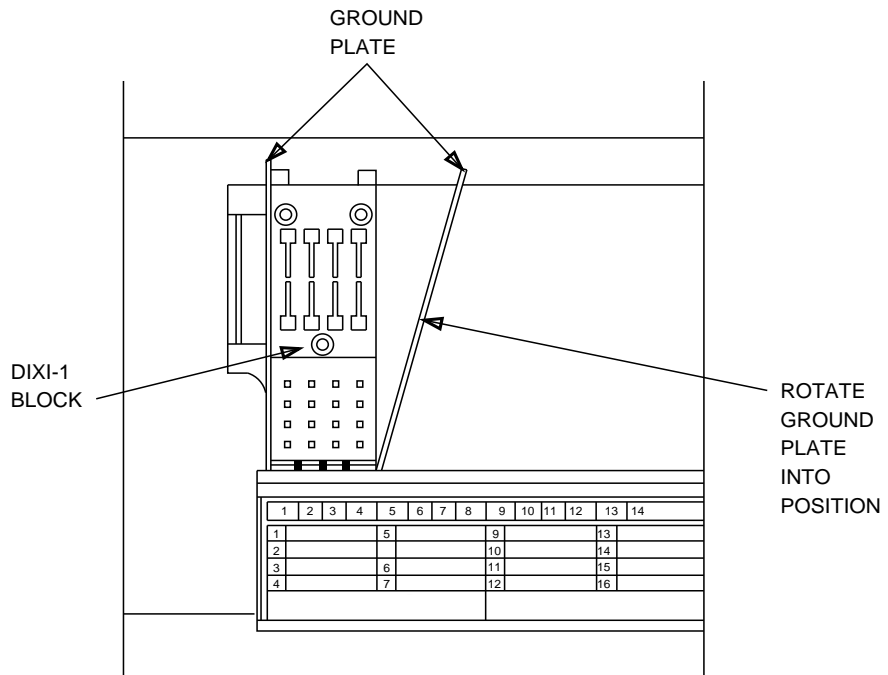

tpa 848424/06

Figure 6. Install Ground Plates

STEP 6—ROUTE NETWORK ELEMENT CABLING TO DIXI-1 PANELS

Refer to Figure 7.

1. Route Network Element cabling into proper clamping block in ETSI cabinet (see Figure 1).
2. Butt and strip cable allowing conductor length a minimum of 914 mm (36 inches).
3. Secure cable to round rods with twine or nylon ties.
4. Partition conductors to each block position through transition panel.
5. Cut remaining conductors to a length of 152 mm (6 inches) from top edge of designation strip.

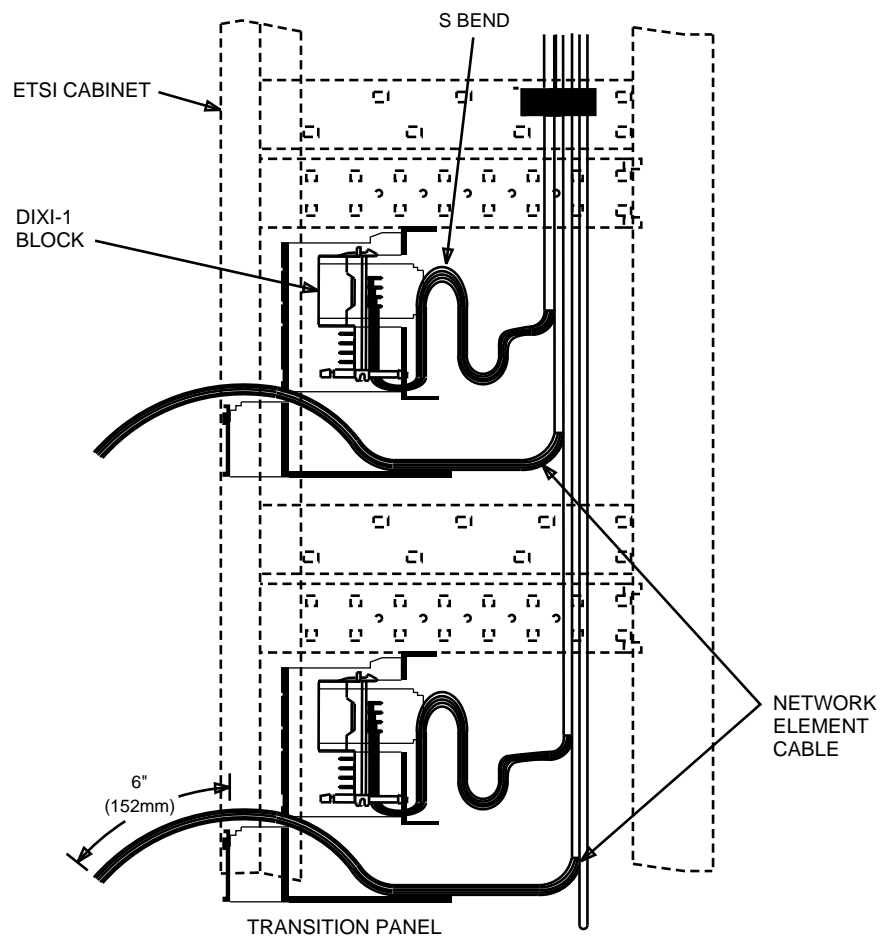

tpa 848424/07

Figure 7. Route Network Element Cabling

STEP 7—CONNECT NETWORK ELEMENT WIRING TO DIXI-1 BLOCKS

Refer to Figure 8.

1. Pull free end of Network Element cabling (wiring) over fanning strip and up across the front of each block. Each block requires its own conductor group.
2. Strip conductors and wire-wrap them to corresponding terminals. Ground (drain) wire for each shielded pair is wrapped to a terminal on the adjacent ground plate. Transmit circuits terminate on *IN* pins (bottom two rows), and receive circuits terminate on *OUT* pins (top two rows).
3. Dress terminated conductors by snapping them through slotted fanning strip.

NOTE: DCS CABLING INSTALLED IN PREVIOUS STEP
AND REAR CABLE BRACKET ARE NOT SHOWN

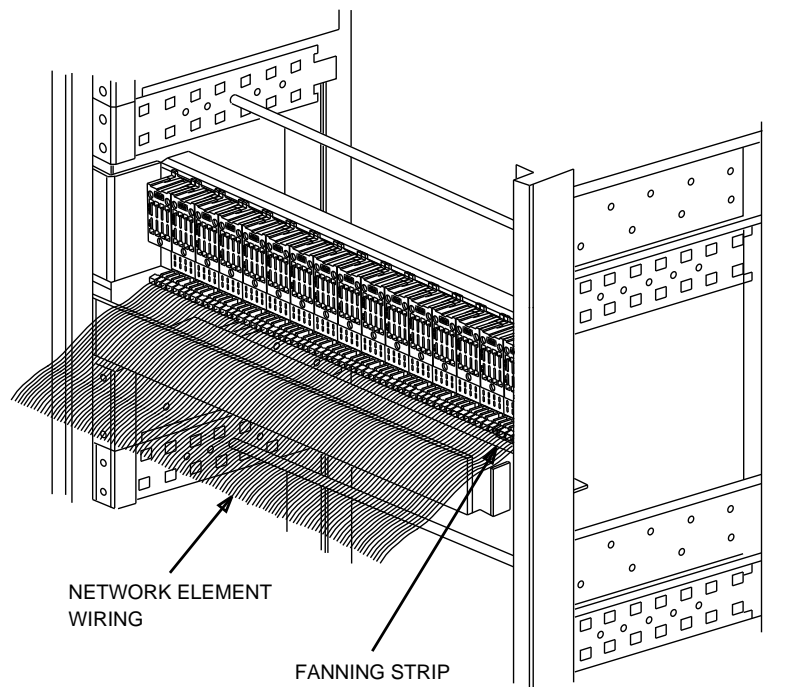

tpa 848424/08

Figure 8. Connecting Network Element Cabling

80 CIRCUIT CROSS-CONNECT PANEL INSTALLATION AND CABLING

Equipment Description

The 80-circuit DIXI-1 cross-connect panel can accommodate 20 DIXI-1 blocks with 20 DIXI-GR1A ground plates (80 circuits total). An empty version of the panel is also available for customized capacity with separately orderable DIXI-1 blocks and DIXI-GR1A ground plates (see Figure 10 on page 13).

STEP 1—DETERMINE PANEL MOUNTING POSITION

Figure 9 shows the recommended panel mounting positions, framework hardware positions, and cabling method for the DIXI-1 cross-connect panels. This panel is also referred to as the “5-Inch (127 mm) Panel.”

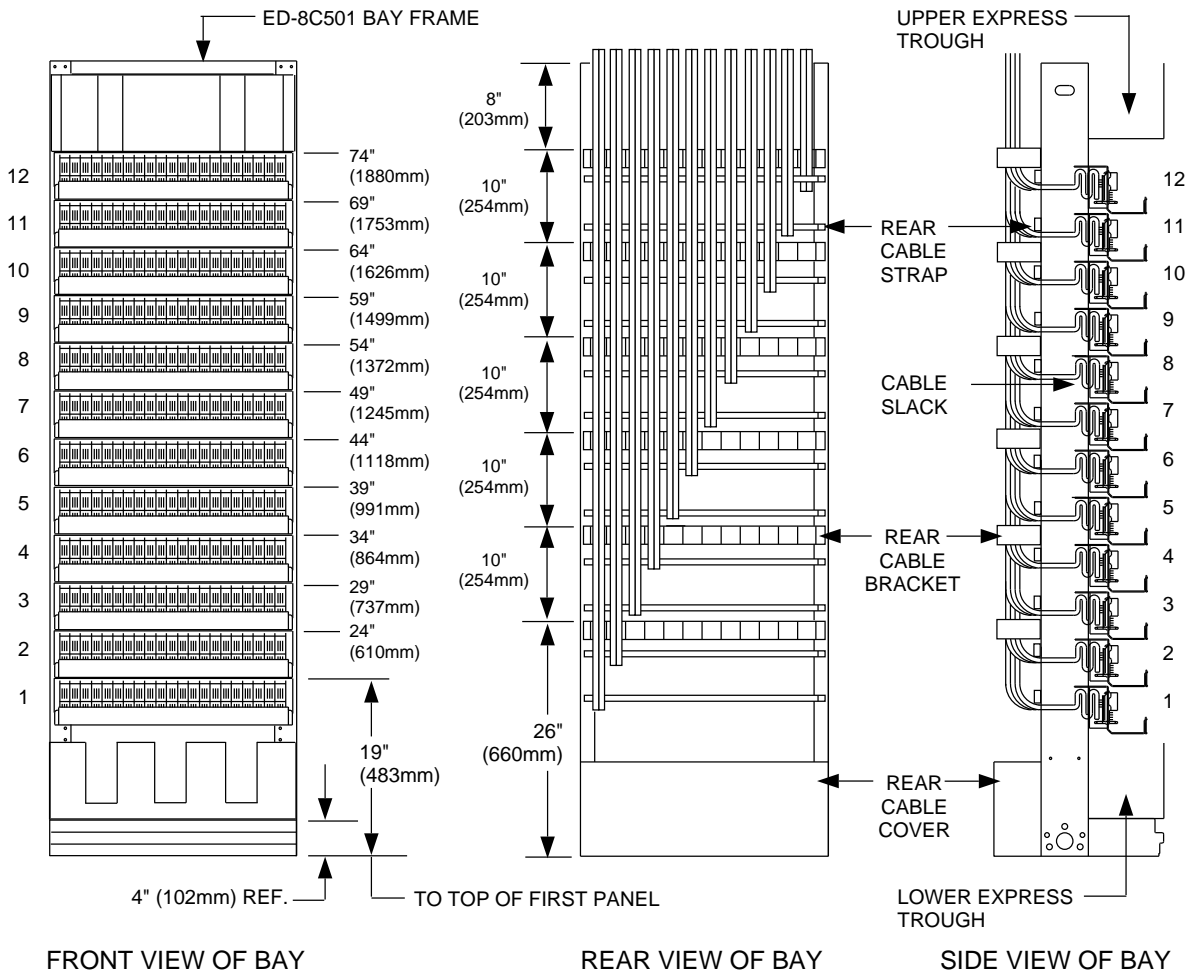

Figure 9. 80 Circuit Cross-Connect Panel and Framework Hardware Mounting Positions

STEP 2—INSTALL CROSS-CONNECT PANEL ASSEMBLY

Refer to Figure 10.

1. Locate panel mounting position on wide flange side of bay frame and secure panel bracket with four #12-24 UNC by 0.375-inch (5.48 by 9.53 mm) screws provided.
2. Mount rear cable strap on narrow flange side of bay frame and secure with two #12-24 UNC by 0.375-inch (5.48 by 9.53 mm) screws provided.
3. Slide the equipment designation label and clear cover into the designation strip on the transition panel.

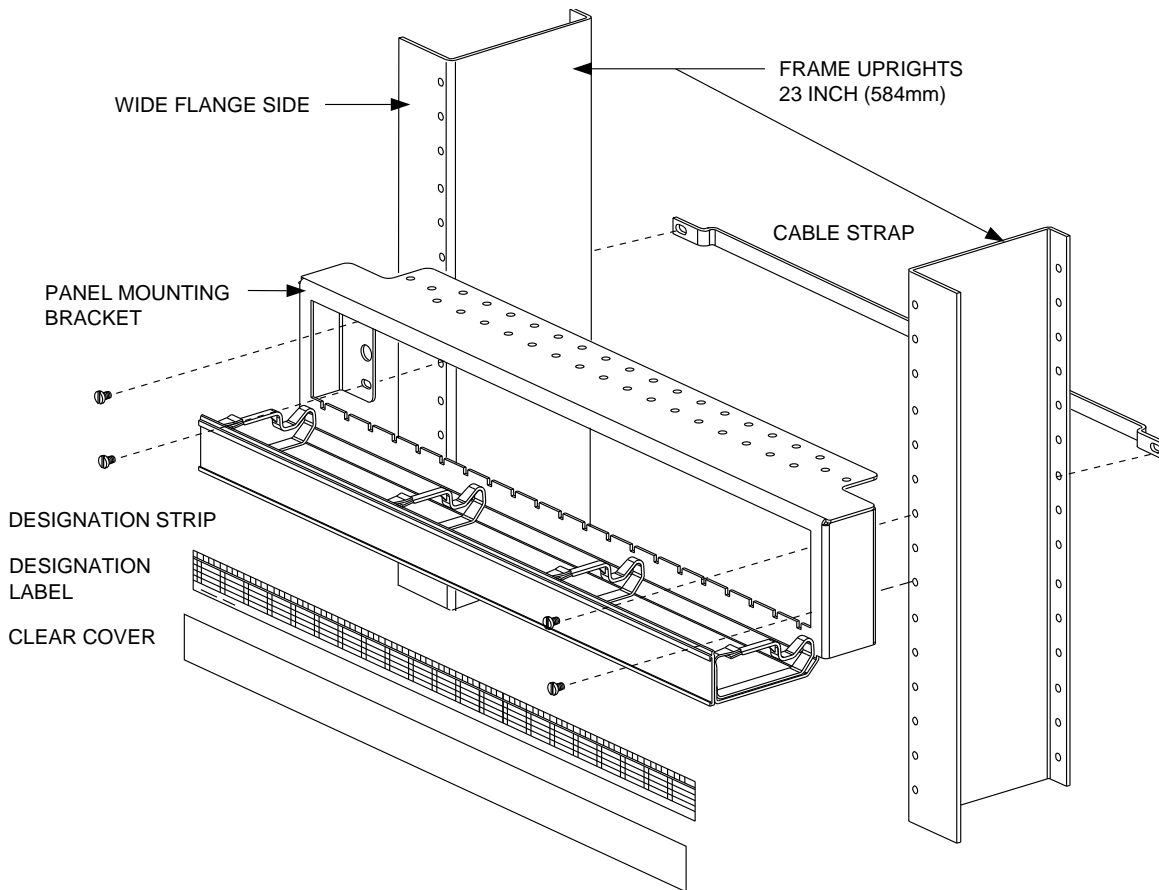

Figure 10. Install DIXI-1 80 Circuit Cross-Connect Panel Assembly

STEP 3—ROUTE CABLING TO DIXI-1 PANELS

Refer to Figure 11.

1. Route cabling into proper slot of rear cable bracket. Each slot (total of 12) is associated with a panel position.
2. Butt and strip cable 13 mm (1/2 inch) below cable bracket for panel closest to cable bracket, allowing conductor length a minimum of 914 mm (36 inches).
3. Butt and strip cable for second panel approximately 152 mm (6-1/2 inches) below cable bracket, allowing conductor length a minimum of 914 mm (36 inches).
4. Secure cable to cable bracket with twine or nylon ties.
5. Partition conductors to each block position and secure to rear cable strap with twine or nylon ties.
6. Cut remaining conductors to a length of 508-584 mm (20-23 inches) from secured position on cable strap.

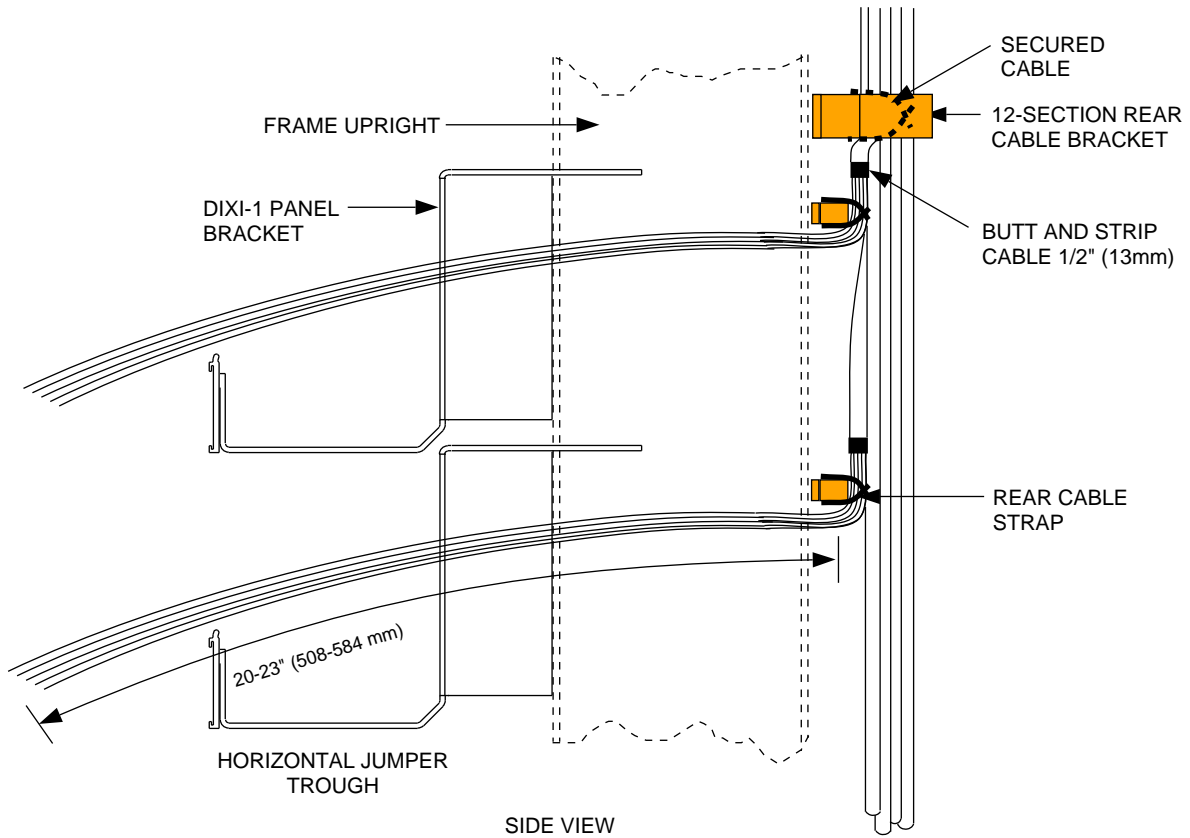

Figure 11. Route Panel Cabling

STEP 4—CONNECT CABLING TO BLOCKS

Refer to Figure 12 and Figure 13 on page 16.

1. Hang ground plates and blocks (starting with a ground plate, working left to right, one plate per block) on the designation strip of the panel bracket with rear of block facing out. When hung in this position, the circuit termination identification on the rear of the block is “left-to-right” to aid wiring operations.
2. Secure blocks to the horizontal jumper trough with lacing cord.
3. Pull free end of formed cable legs and dress conductors over fanning strip and down across the rear of the block. Each block requires its own conductor group.
4. Strip conductors and wire-wrap them to corresponding terminals. Transmit circuits terminate on *OUT* pins and receive circuits terminate on *IN* pins. Wrap ground (drain) wire for each pair to a pin on the adjacent ground plate. If both transmit and receive circuits are connected, then each pin of the ground plate will hold two ground wires. The fifth pin on the ground plate is to allow all ground plates to be daisy-chained together in a common ground circuit. When daisy-chaining ground plates leaves a minimum 254 mm (10-inch) loop of wire between adjacent plates to allow the removal of an individual plate from a completed assembly.

If necessary see T-6C100-12, Common Systems Digital Transmission Facilities, DIXI-1 Interconnection Circuit for more detailed cabling information.

5. Dress terminated conductors by snapping them through slotted fanning strip.

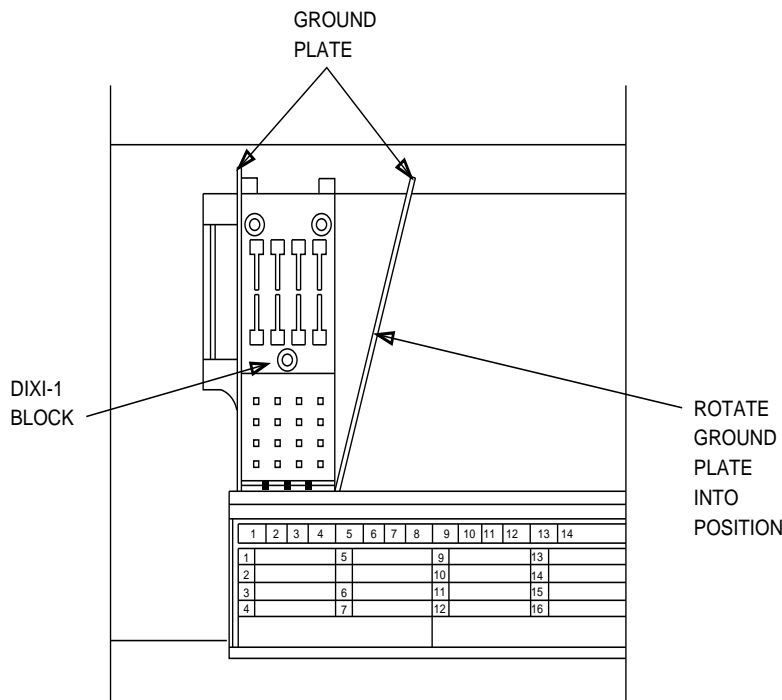

tpa 848424/06

Figure 12. Hang Ground Plates and Blocks

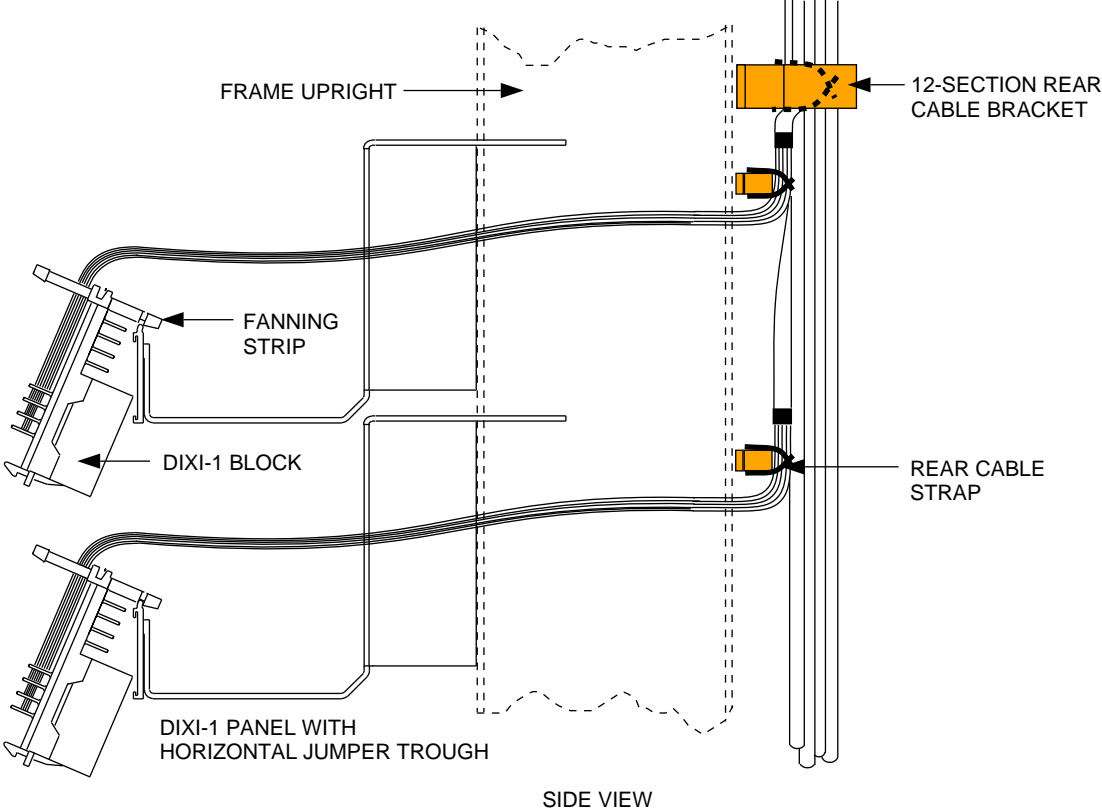

Figure 13. Connecting Cabling to Blocks

STEP 5—FORM CABLE AND INSTALL BLOCKS

Refer to Figure 14.

1. Cut lacing cord securing blocks.
2. Form cable slack (S bend) and secure with twine or nylon ties. Leaving slack simplifies future block replacement and DCS circuit redistribution procedures.
3. Install a ground plate at the left end of the panel by placing the notch at the bottom of the ground plate onto the sawtooth edge of the panel and rotate it into place. Ground plates must be cocked slightly to the side and rotated into a vertical position with the spring loaded notch capturing the top edge of the panel opening (see Figure 13). *All ground plates must be constrained*, either between two DIXI blocks, or between a DIXI block and one of the tabs at either end of the panel. Installation should start from the left side and work to the right.
4. Lift and rotate a DIXI block into place beside the ground plate. Place the slot at the bottom of each fanning strip onto sawtooth ledge of panel and rotate into place.
5. Push block into opening of panel bracket until latch on block *snap-locks* into panel bracket.
6. Repeat the above processes to install ground plates and DIXI blocks across the panel, sandwiching ground plates between DIXI blocks.
7. Verify all blocks are properly installed by grasping each block at top and pulling from the front with a moderate force of approximately 4.5 kg (10 pounds).

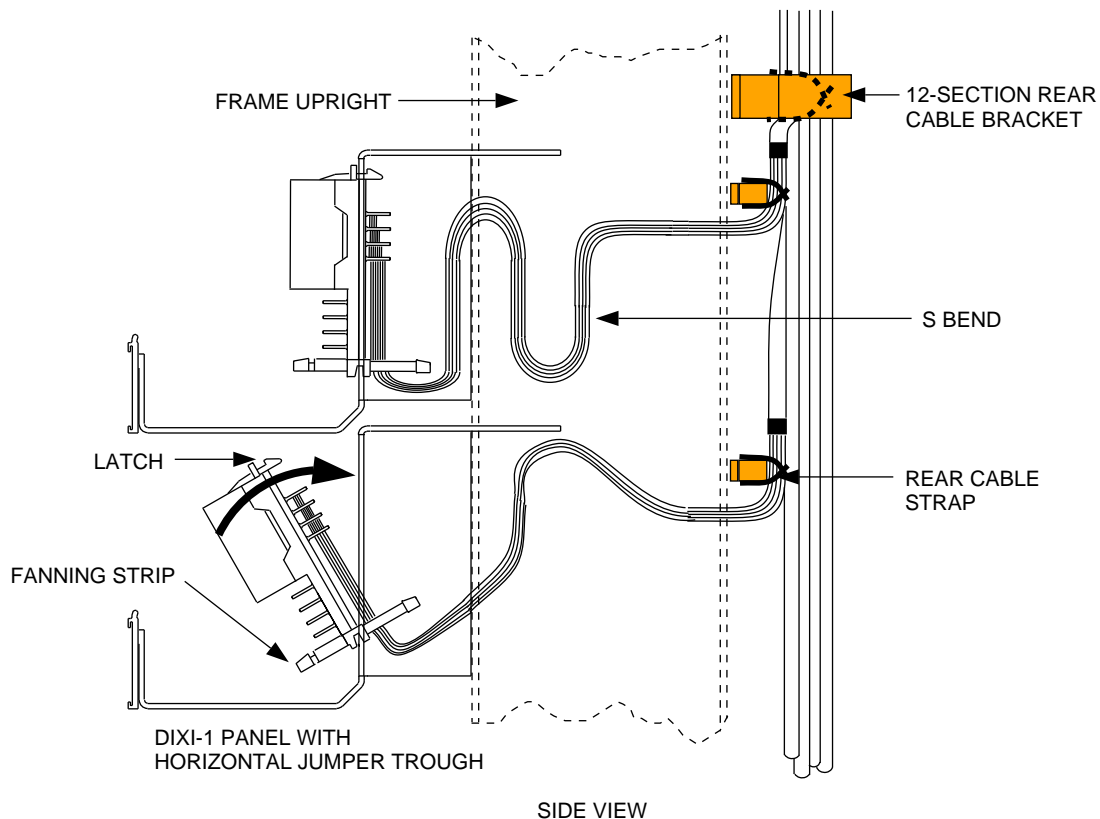

Figure 14. Form Cable Slack and Install Blocks