

Refer to Z-IDC Reference Manual, 201-205-001, for additional information.

General

This instruction sheet provides the description and installation procedures for the Z-IDC Interconnect System Voltage Limiting Only Cartridge Protectors Installation.

Verify parts according to the Parts List shown below. Report any damaged or missing parts to your local Avaya representative.

NOTE:

Nine digit Material ID ordering numbers do not contain spaces. They are included here for ease of reading.

How to Contact Us

- To find out more about **Carrier Apparatus** products, visit us on the web at: <http://cw.commscope.com/>
- For technical assistance regarding Carrier Apparatus products: contact your local CommScope account representative or CommScope technical support at 1-800-344-0223.
- Report any missing or damaged parts to CommScope customer service in Omaha, Nebraska, at 1-866-539-2795.

Correct Cartridge Protector Must Be Used For Connector Module Pair Count

- Exclusion feature prevents incorrect installation of 8-pair Cartridge Protector on 10-pair Connector Module.

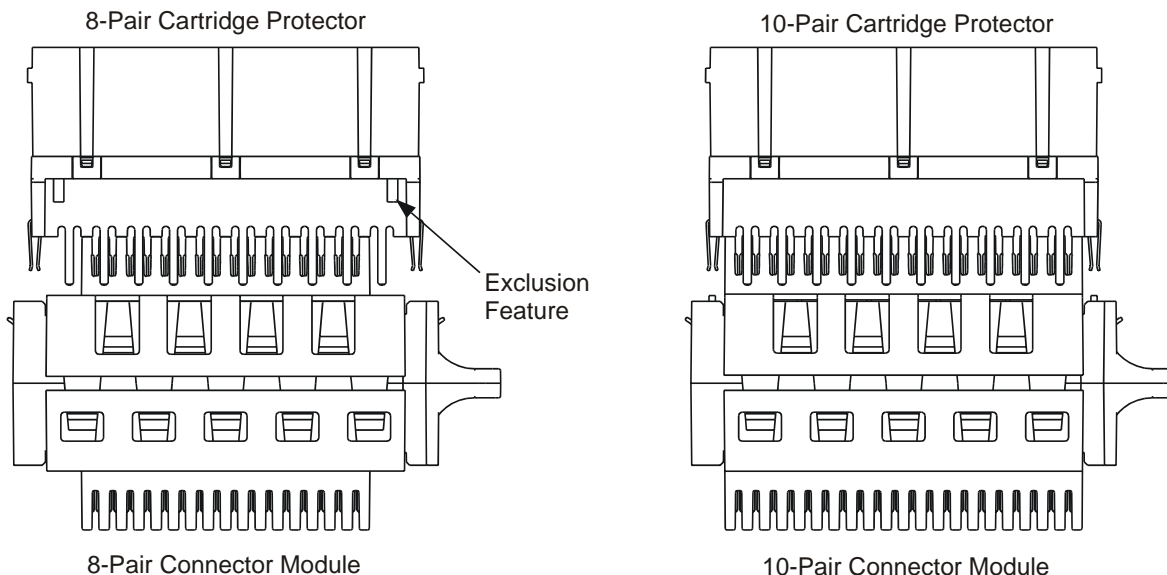

Figure 1. 8-pair Cartridge Protector on 10-pair Connector Module.

Installing Cartridge Protector Onto Connector Module

1. Cartridge Protector must seat against Connector Module
2. Ground bar contacts must engage mounting bracket tabs
3. Cartridge Protector can be installed on front or rear of Connector Module.

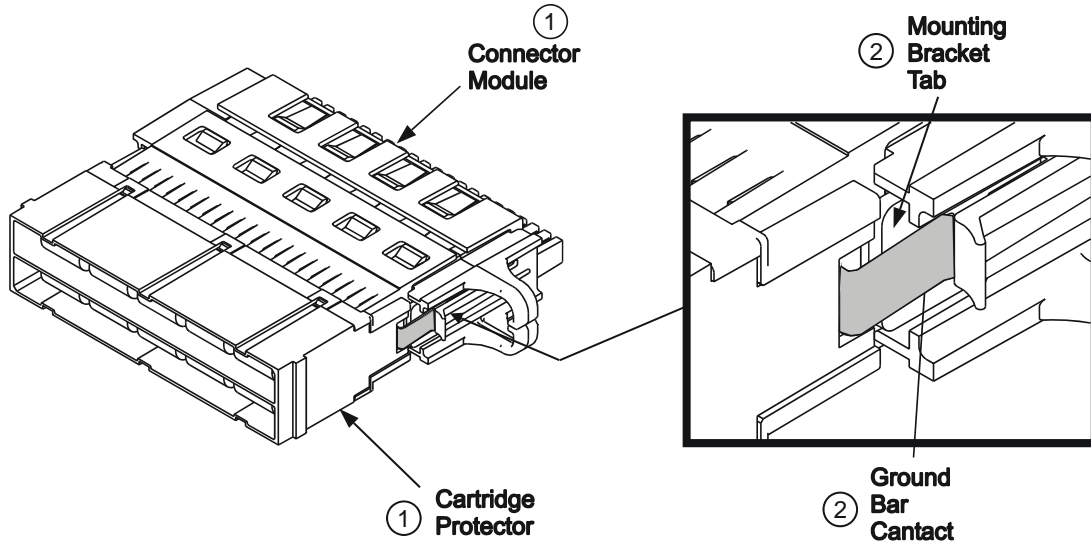

Figure 2. Installing Cartridge Protector

Removing Cartridge Protector From Connector Module

1. Pull Cartridge Protector away from Connector Module

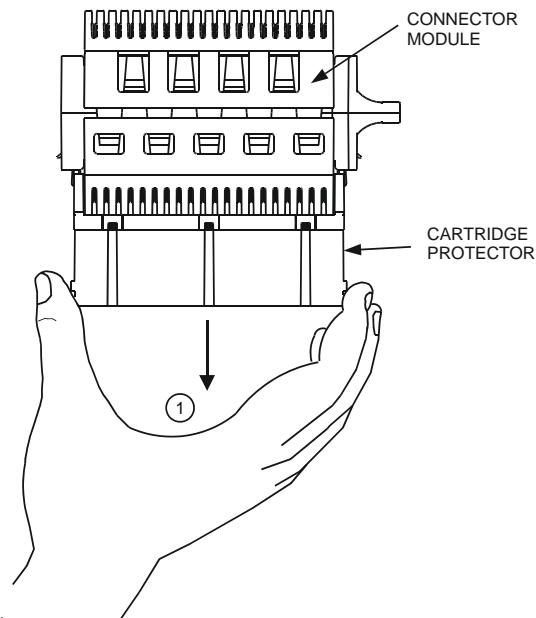

Figure 3. Removing the Cartridge Protector

Installing And Removing Gas Tubes In Cartridge Protector

Warning: High voltage may be present

1. Use pliers with insulated handles.
2. Align pin on one end of gas tube with hole in Cartridge Protector to aid installation.

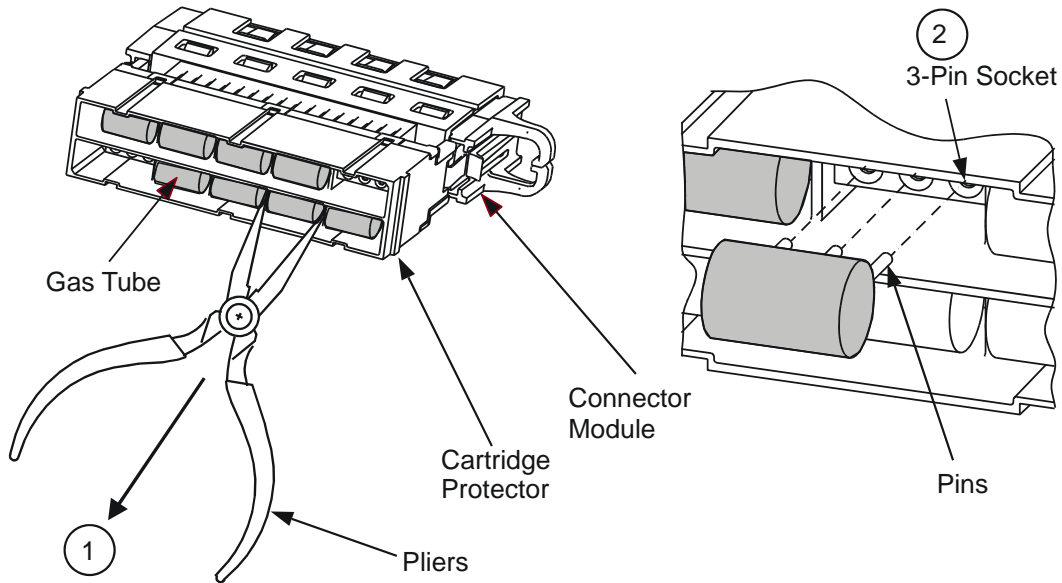

Figure 4. Removing and Installing Gas Tubes

Numbering Of Gas Tubes In Cartridge Protector

1. Corner triangle indicates beginning and end of circuit pair count.

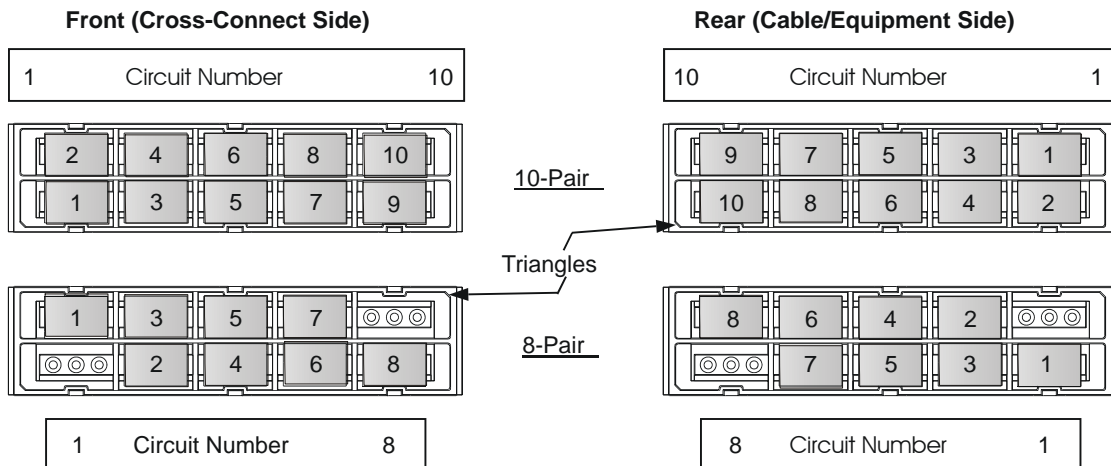

Figure 5. Numbering of Gas Tubes

Installing/Removing (Optional) Cover For Cartridge Protector

1. Push cover latches onto Cartridge Protector to install cover
2. Lift and release cover latches to remove cover.

Material ID 847 673 035
Instruction Sheet

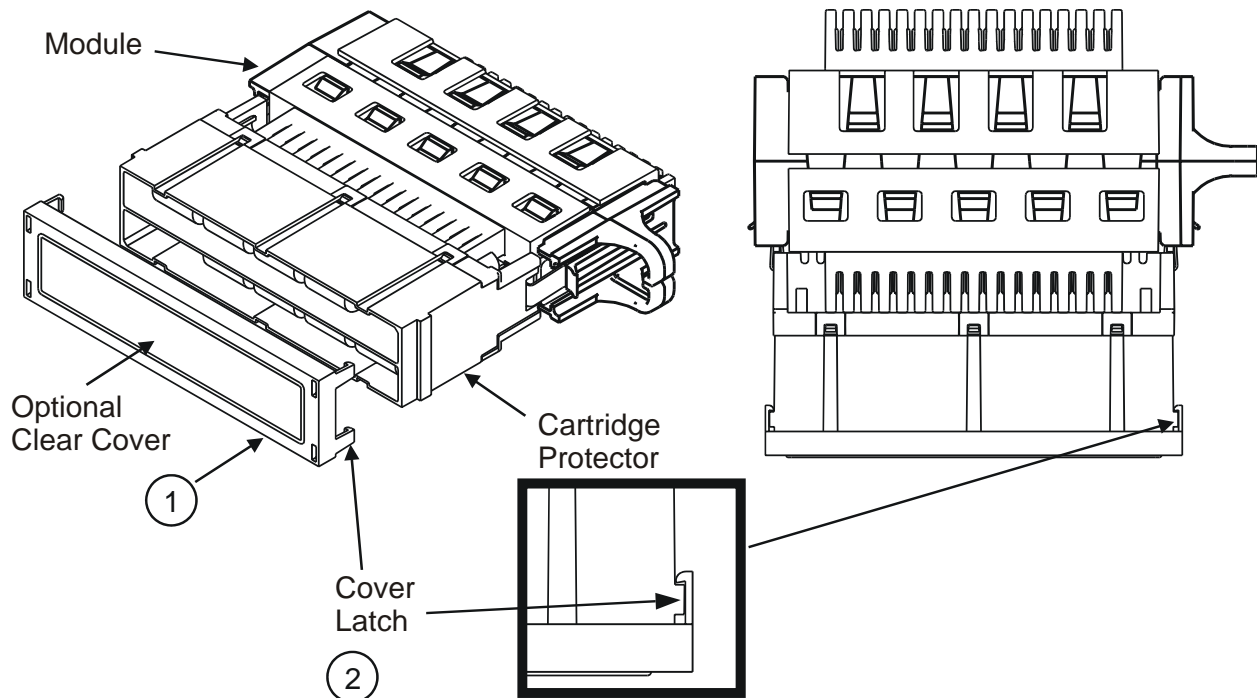

Figure 6. Installing and Removing Cover

Ordering Information

Description	Apparatus Code	Material ID
8-pair Cartridge Protector, black, 3-element gas tube, 180 - 300 V (order in multiples of 8)	ZIDC-08-G3A-NA-BN	107 650 541
10-pair Cartridge Protector, black, 3-element gas tube, 180 - 300 V (order in multiples of 10)	ZIDC-10-G3A-NA-BN	107 650 566
8-pair Cartridge Protector, black, 3-element gas tube, 230 V \pm 15 % (order in multiples of 8)	ZIDC-08-G3B-NA-BN	107 971 517
10-pair Cartridge Protector, black, 3-element gas tube, 230 V \pm 15 % (order in multiples of 10)	ZIDC-10-G3B-NA-BN	107 971 525
Package of 100 replacement 3-element gas tubes for cartridge protector, 180-300 V, with fail-safe	ZIDC-G3A-100	107 660 474
Package of 100 replacement 3-element gas tubes for cartridge protector, 230 V \pm 15 %, with fail-safe	ZIDC-G3B-100	107 973 463
Package of ten clear dust covers for 8- or 10-pair cartridge protector	ZIDC-CCC-010	107 660 532