

General

This instruction sheet provides procedures for installing a 307 protector panel flame guard.

- Refer to pages two and three for instructions on how to install the protector panel flame guard.

How to Contact Us

- To find out more about **Carrier Apparatus** products, visit us on the web at:
<http://cw.commscope.com/>
- For technical assistance regarding Carrier Apparatus products: contact your local CommScope account representative or CommScope technical support at 1-800-344-0223.
- Report any missing or damaged parts to CommScope customer service in Omaha, Nebraska, at 1-866-539-2795.

References

- 307-Type Connectors Description, Use, Installation, and Repair Procedures, document number 201-208-110.

Tools Required

- Screwdriver - flat blade

Parts List

Verify parts according to the parts list shown below:

Quantity	Description	Material ID
1	Protector Panel Flame Guard	860130582
2	#10-32 x 0.25 Pan Head Screws	900506882

Installing the 307 Protector Panel Flame Guard

1. Position the flame guard (860130582), see Figure 1, to the bottom rear of the 307 connector aligning the through hole on the flame guard to the second tapped hole on the left and right ground bar as shown in Figure 2.

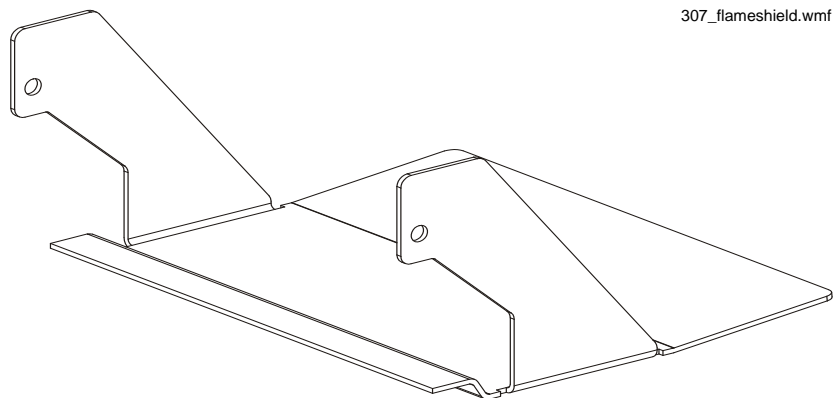

Figure 1. 307 Protector Panel Flame Guard

Fig01_860166644F.jpg

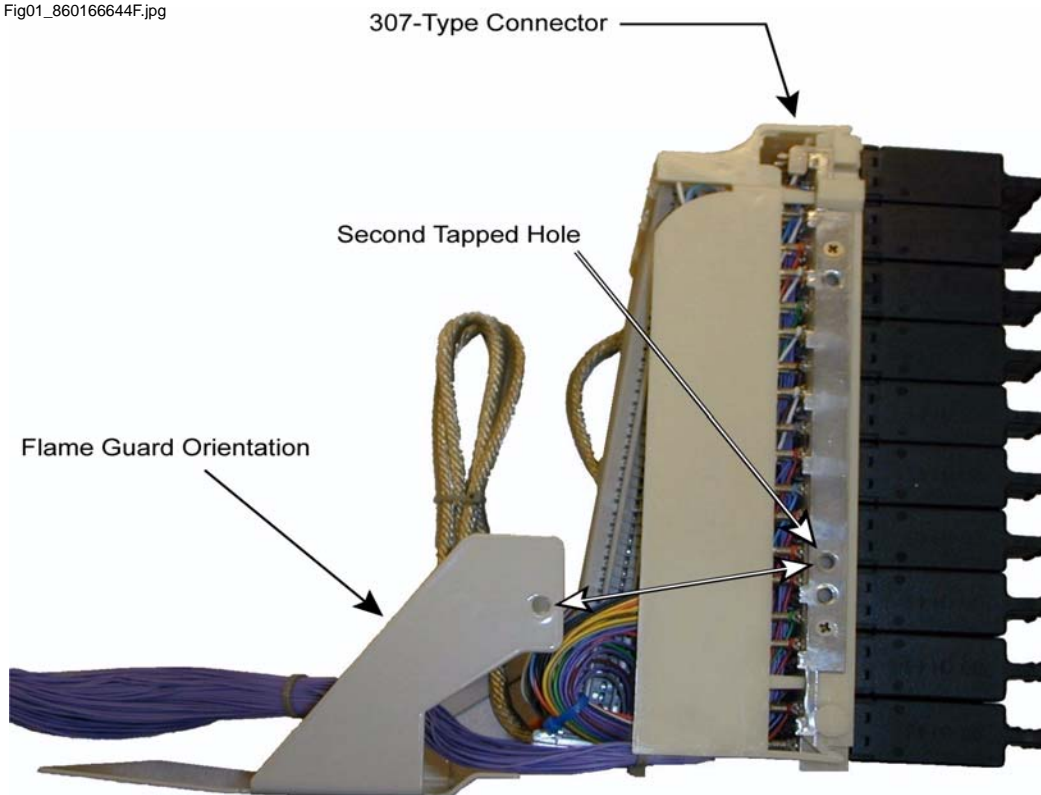

Figure 2. Positioning the Flame Guard for Installation

- Using one of the #10-32 x 0.25 pan head screws (900506882) for each side, attach the flame guard to the 307 connector as shown in Figure 3.

Note: Ensure that the flame guard rests flush with the bottom of the connector. This may require slight force when aligning the bracket as the flame guard is designed with a slight interference fit with the rear bracket of the 307 connector.

Fig02_860166644F.jpg

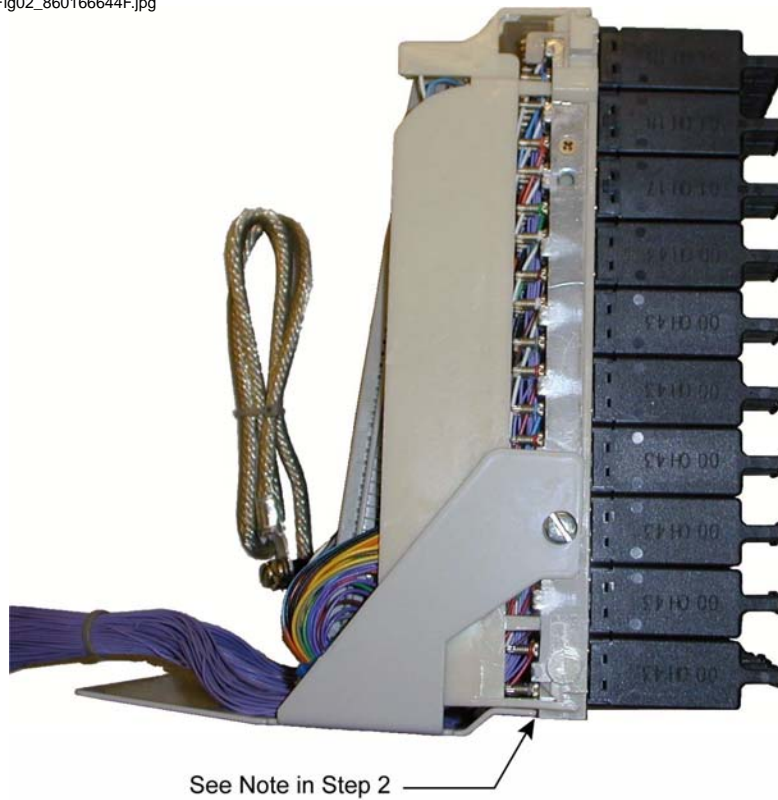

Figure 3. Installation of 307 Protector Panel Flame Guard